



OFFSHORE STAINLESS SUPPLIES | COLD DRAWN BAR MANUFACTURING

COLD DRAWN BAR | MANUFACTURING

NORSOK | MDS D59/D59L



At Offshore Stainless Supplies, we pride ourselves on a high level of service and aim to totally satisfy our customer expectations. We use a variety of manufacturing technologies to meet customer requirements in a safe and environmentally friendly manner, with a 'right-first-time' approach.

We also have a long-standing and highly skilled workforce who understand our manufacturing capabilities and have pride in every cold drawn bar supplied.



We are fully ISO 9001 accredited – the world's most recognised Quality Management System, plus we are members of the BVAA (British Valve & Actuator Association) and the IWMA (International Wire & Machinery Association), which are both influential corporate associations in their industries.

All this complements our recent NORSOK accreditation and approval to produce UNS 32760 Super Duplex strain hardened bars for fasteners to MDS D59/D59L Rev 3.

NORSOK standards are developed by the Norwegian petroleum industry to ensure adequate safety, value adding and cost effectiveness for petroleum industry developments and operations.

Offshore Stainless Supplies are the only cold drawn bar manufacturer in the UK to be awarded this prestigious accreditation, reinforcing our position as the UK's most trusted and reputable manufacturer and stockholder of cold drawn stainless steel and nickel alloy bars.



CONTENTS | PAGES

10–31

Stainless Steel

304	1.4301
304L	1.4307
316	1.4401
316L	1.4404
316 Ti	1.4571
316L Mo>2.5%	1.4435
321	1.4541
UNS S31254	1.4547
347	1.4550

32–39

Super Duplex

UNS 32760	1.4501
UNS 32750	1.4410

40–43

Duplex

UNS S20910	1.3964
UNS S31803	1.4462

44–54

Nickel Alloys

C22	2.4602
C276	2.4819
400	2.4360
K500	2.4375
625	2.4856
718	2.4668
725	2.7725
X750	2.4669
825	2.4858

ABOUT OUR COMPANY



57,000 SQ.FT.
TOLLPOINT

‘Drawn
to
Quality’

The Ultimate in Cold Drawn Bar Manufacturing

Offshore Stainless Supplies Ltd is the UK’s most trusted and reputable manufacturer and stockholder of cold drawn stainless steel and nickel alloy bars.

Founded in 1999, we process a range of cold-drawn round, hexagon, square and flat bar sections, offering bespoke sizes, special lengths and high tensile strengths from our production facility in the West Midlands.

Tel: +44 (0)1922 414003
Email: sales@offshorestainless.co.uk

Specialising in duplex, super duplex, nickel alloys and other exotic grades and with a huge stock inventory, Offshore Stainless Supplies can produce lengths of up to 10.8 metres from rod coils and up to 16 metres on our bar-to-bar draw benches, with specific mechanical properties and close tolerances.

We offer customised solutions to meet our customer’s specific requirements for unique products such as fasteners, valve bodies, manifolds and spring making applications, supplying products to more than 50 countries worldwide.

OUR PRODUCT PORTFOLIO

Today, we are recognised as the quality standard in cold drawn bar having been manufacturing high quality product for over 25 years.

We serve many different markets, including offshore, nuclear, oil and gas, marine, transportation, automotive and construction.

Stock Holding

We take pride in our state-of-the-art manufacturing facility that boasts both impressive stock holding and production capacities. We hold 1,500 tonnes of cold drawn sizes on the shelf rather than being manufactured on a leadtime.

Whether you require standard sizes or custom specifications, our facilities are equipped to fulfill orders of any scale with precision and reliability. With access to over 4,000 tonnes of group inventory of Stainless Steel, Duplex and Nickel Alloy grades, together with recent investments in our cold drawing machinery and production facilities, we can now offer best-in-class delivery times of typically 2 to 4 weeks for cold drawn product.

Technical Sales Team

We like nothing more than learning about the uses of our strain hardened bars, and working with our customers to support the engineering challenges they present to us. For further details contact our Technical sales team to discuss how we can meet your project requirements.



35,000 SQ.FT.
BURNTWOOD

Added-Value Services

We offer finishing process where a high-quality surface finish is applied to not only improves the aesthetics of the stainless steel bars and can contribute to better corrosion resistance and overall performance in various applications.

Roll marking is also a cost-effective and efficient service we also offer to add information to the surface of bars during the manufacturing process, to provide a permanent and visible means of conveying important details about the bars, facilitating proper handling, usage, and quality control.

We hold substantial inventories of raw materials, enabling us to respond swiftly to customer demands.

OUR STOCK LIST

GRADES:	EN:	COLD DRAWN TO:
---------	-----	----------------

STAINLESS STEEL

Round Bar: $\varnothing 7.925 - 99.44\text{mm}$ (0.312 - 3.915")		
304 / 304L	1.4301 / 1.4307	A2-70 / A2-80 / A2-100
304 / 304L	1.4301 / 1.4307	ASTM A193/A320 B8 CLASS 2, CLASS 2B, BS 4882, B8X
316 / 316L	1.4401 / 1.4404	A4-70 / A4-80 / A4-100
316 / 316L	1.4401 / 1.4404	ASTM A193/A320 B8M CLASS 2, CLASS 2B, CLASS 2C, BS 4882, B8MX
316 TI	1.4571	A5-70 / A5-80
316L MO>2.5%	1.4435	1.4435 CLASS 70 / CLASS 80
321	1.4541	ASTM A193/A320 B8T CLASS 2, BS 4882, B8TX
UNS S31254	1.4547	ASTM A193/A320 B8MCUN CLASS 2 / 31254 CLASS 80
347	1.4550	ASTM A193/A320 B8C CLASS 2

Hexagonal Bar: $10 - 55\text{mm}$ (0.375 - 2.165")		
304 / 304L	1.4301 / 1.4307	A2-70 / A2-80 / A2-100
304 / 304L	1.4301 / 1.4307	ASTM A193/A320 B8 CLASS 2, CLASS 2B, BS 4882, B8X
316 / 316L	1.4401 / 1.4404	A4-70 / A4-80 / A4-100
316 / 316L	1.4401 / 1.4404	ASTM A193/A320 B8M CLASS 2, CLASS 2B, CLASS 2C, BS 4882, B8MX
316 TI	1.4571	A5-70 / A5-80
316L MO>2.5%	1.4435	1.4435 CLASS 70 / CLASS 80
321	1.4541	ASTM A193/A320 B8T CLASS 2, BS 4882, B8TX
UNS S31254	1.4547	ASTM A193/A320 B8MCUN CLASS 2 / 31254 CLASS 80

Square Bar: $25.4 - 76.2\text{mm}$ (1-3")		
316L	1.4404	NACE MR0175

Flat Bar: $31.75 \times 25.4\text{mm} - 88.90 \times 44.45\text{mm}$ (1.25 x 1" - 3.5 x 1.75")		
316L	1.4404	NACE MR0175

SUPER DUPLEX STEEL

Round Bar: $\varnothing 11.38 - 99.44\text{mm}$ (0.448 - 3.915")		
UNS 32760	1.4501	NORSOK MDS D59/D59L REV 3*
UNS 32760	1.4501	32760 FG, FLT, CONDITION S
UNS 32750	1.4410	32750 FG, FLT, CONDITION S

* Maximum diameter size 86.74mm (3.415")

GRADES:	EN:	COLD DRAWN TO:
---------	-----	----------------

DUPLEX STEEL

Round Bar: $\varnothing 11.38 - 99.44\text{mm}$ (0.448 - 3.915")		
UNS S20910/XM19	1.3964	CUSTOMER SPECIFICATIONS
UNS S31803	1.4462	CUSTOMER SPECIFICATIONS

NICKEL ALLOYS

Round Bar: $\varnothing 7.925 - 99.44\text{mm}$ (0.312 - 3.915")		
C22	2.4602	CUSTOMER SPECIFICATIONS
C276	2.4819	CUSTOMER SPECIFICATIONS
400	2.4360	CUSTOMER SPECIFICATIONS
K500	2.4375	CUSTOMER SPECIFICATIONS
625	2.4856	CUSTOMER SPECIFICATIONS
718	2.4668	CUSTOMER SPECIFICATIONS
725	2.7725	CUSTOMER SPECIFICATIONS
X750	2.4669	CUSTOMER SPECIFICATIONS
825	2.4858	CUSTOMER SPECIFICATIONS

Hexagonal Bar: $10 - 55\text{mm}$ (0.375 - 2.165")		
C22	2.4602	CUSTOMER SPECIFICATIONS
C276	2.4819	CUSTOMER SPECIFICATIONS

Square Bar: $25.4 - 76.2\text{mm}$ (1-3")		
C22	2.4602	CUSTOMER SPECIFICATIONS
C276	2.4819	CUSTOMER SPECIFICATIONS

Flat Bar: $31.75 \times 25.4\text{mm} - 88.90 \times 44.45\text{mm}$ (1.25 x 1" - 3.5 x 1.75")		
C22	2.4602	CUSTOMER SPECIFICATIONS
C276	2.4819	CUSTOMER SPECIFICATIONS

* Other Nickel Alloy grades available upon request

Larger sizes may be available upon application.

Our cutting-edge technology, skilled workforce and advanced infrastructure allows us to efficiently cold draw large volumes of materials, ensuring seamless operations and enabling us to respond swiftly to customer demands.



OUR BAR PROPERTIES

Cold drawn bar manufacturing is a process used to produce steel bars with improved mechanical properties and dimensional accuracy.

The manufacturing process involves pulling (drawing) an oversized bar through a carbide die at room temperature (i.e. cold-drawn). This mechanical process results in a reduction in diameter and an improvement in the surface finish of the steel bar.

After cold drawing, the steel bar will go through a straightening process to ensure it meets specified dimensional tolerances. It is then cut into the desired lengths. The cold drawing process also imparts several benefits to the steel, including:

Increased Mechanical Properties:

Cold drawing can enhance the mechanical properties of the steel, such as strength and hardness, due to the strain hardening effect.

Improved Dimensional Accuracy:

Cold drawing ensures tight dimensional tolerances, producing steel bars with precise diameters.

Enhanced Surface Finish:

The process results in a smooth and clean surface, reducing the need for additional finishing processes.

Better Surface Integrity:

The cold drawing process improves the surface integrity of the steel, making it more suitable for applications where surface quality is critical.

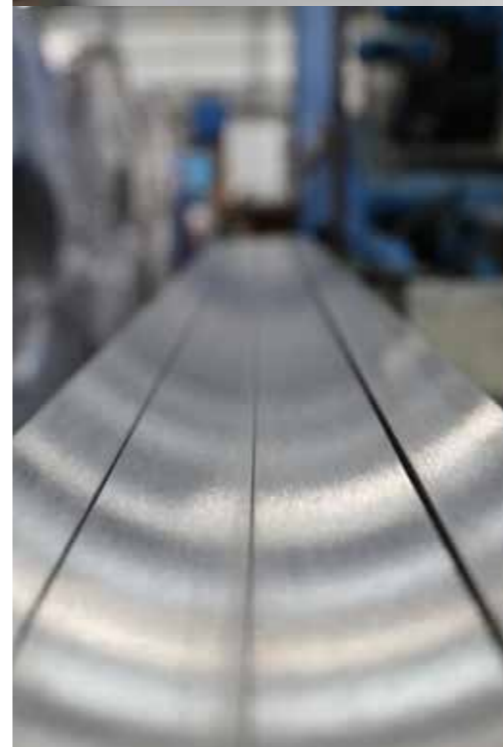
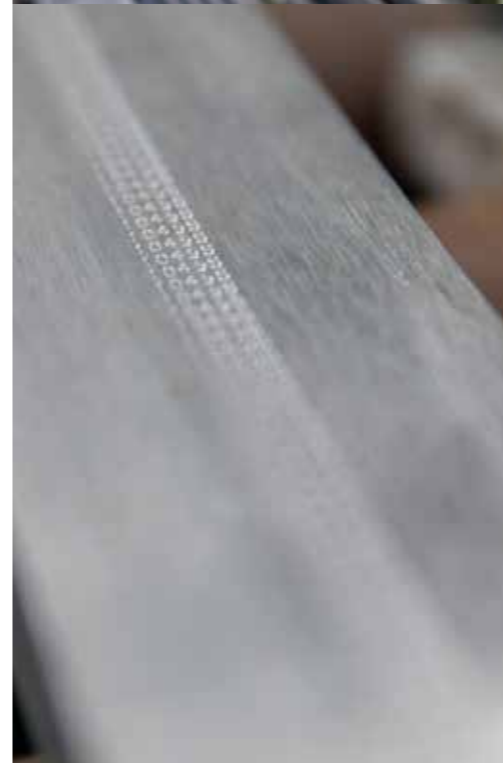

OUR BAR DIMENSIONS

Cold drawn bars can be produced in various shapes and dimension depending on the intended use of the bar and the specific requirements of the application to meet the needs of various industries and applications:



Up to 3.915"
Diameter

Round Bars:

These are cylindrical bars with a circular cross-section with precise diameter tolerances.



Up to 2.165"
A/F

Hexagonal Bars:

Hex bars have a hexagonal (six-sided) cross-section, with uniform sides and sharp corners.



Up to 3"
HxW

Square Bars:

Bars with a square cross-section that are commonly used in applications where a more geometrically defined shape is required.

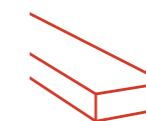

Up to
3.5 x 1.75"
HxW

Flat Bars:

Producing flat bars with a rectangular cross-section, often used in valves, manifolds and engineering applications.

Offshore Stainless Supplies are the only UK company who can cold draw Stainless Steel, Super Duplex and Nickel Alloy bars above $\text{Ø}2.5$ ". In fact, we have the capability to draw from up to $\text{Ø}4.0$ " due to the size and power of our draw benches.

This is in addition to offering the UK's market-leading, largest profile sizes across square, hexagonal and flat bar sections.

OUR MARKETS |

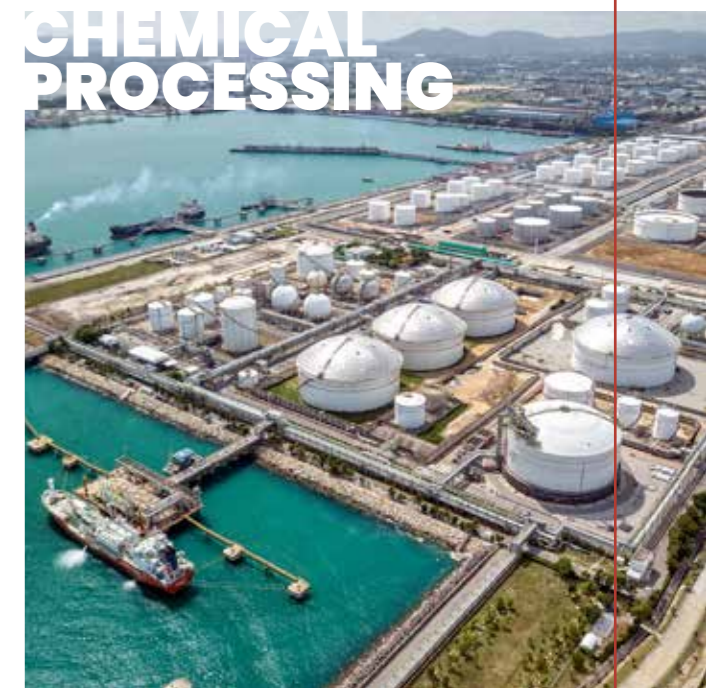
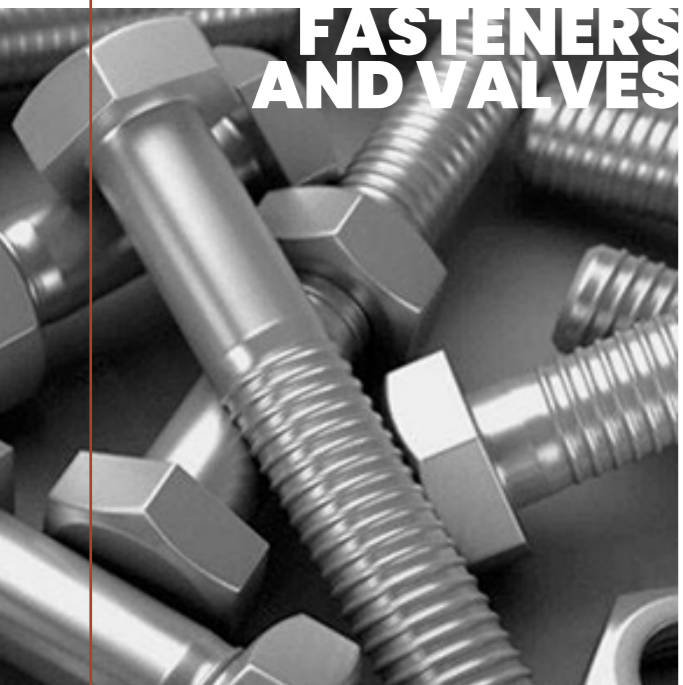
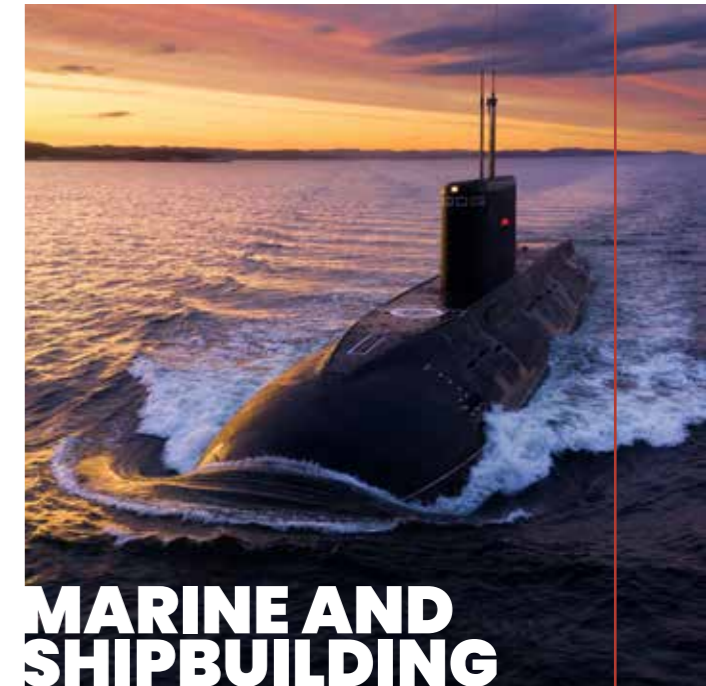

Delivering to over
50 countries worldwide

STAINLESS STEEL

Stainless steel, including austenitic stainless steel, is popular for its strength, durability and corrosion resistance. It is aesthetically pleasing, easy to produce, clean and maintain. It is also environmentally friendly and environmentally sustainable with a high-recycled content and long service life, making it a top choice for many products including fasteners, manifolds and shafts.

However there is more than one kind. Stainless Steel is actually a broad term used to refer to iron-based alloys which contain chromium, and there are more than 100 grades of stainless steel. These are differentiated by the percentage of chromium, nickel, molybdenum and other alloying elements. Each grade is used for specific purposes and comes with its own advantages and disadvantages.

There are several types and grades of stainless steel, and the choice of grade depends on the intended use and specific requirements. The grades are grouped within 5 main categories: austenitic, ferritic, martensitic, duplex and precipitation-hardened (PH).



GRADES:

304 / 304L	1.4301 / 1.4307
304 / 304L	1.4301 / 1.4307
316 / 316L	1.4401 / 1.4404
316 / 316L	1.4401 / 1.4404
316L	1.4404
316Ti	1.4571
316L Mo>2.5%	1.4435
321	1.4541
UNS S31254	1.4547
347	1.4550

COLD DRAWN TO:

A2-70 / A2-80 / A2-100
ASTM A193/A320 B8 Class 2 Class 2B, BS 4882, B8X
A4-70 / A4-80 / A4-100
ASTM A193/A320 B8M Class 2, Class 2B, Class 2C, BS 4882, B8MX
NACE MR0175
A5-70 / A5-80
1.4435 Class 70 / Class 80
ASTM A193/A320 B8T Class 2, BS 4882, B8TX
ASTM A193/A320 B8MCuN Class 2 / 31254 Class 80
ASTM A193/A320 B8C Class 2

STAINLESS STEEL

304 – 1.4301 / 304L – 1.4307



304 – 1.4301 / 304L – 1.4307

304 and 304L are both grades of austenitic stainless steel, which is the most widely used type of stainless steel. These grades are very similar, known for their versatility and corrosion resistance, with the main difference being the carbon content. The use of 304L is often preferred in situations where welding is a significant consideration due to its improved weldability and reduced susceptibility to sensitivity.

KEY FEATURES

- Corrosion resistance
- Forming and welding characteristics
- Oxidation resistance

COLD DRAWN TO

A2-70 / A2-80 / A2-100

A2-70 / A2-80 / A2-100

A2-70/80/100 are designated specifications for stainless steel fasteners. The A2 indicates that they are 304 austenitic stainless steel that have been cold drawn to provide a minimum tensile strength of 700 N/mm², 800 N/mm², or 1,000 N/mm², with good corrosion resistance in various environments.

KEY FEATURES

- Good corrosion resistance
- Good mechanical properties
- High strength

BAR SHAPES

ROUND BAR:
Ø7.925 – 99.44mm
(0.312 – 3.915")



HEXAGONAL BAR:
10 – 55mm A/F
(0.375 – 2.165")

CHEMICAL PROPERTIES

	Chromium (Cr)	Nickel (Ni)	Manganese (Mn)	Silicone (Si)	Nitrogen (N)	Carbon (C)	Phosphorus (P)	Sulphur (S)
304	18-20%	8-11%	2%	1%	0.1%	0.08%	0.045%	0.03%
304L	18-20%	8-11%	2%	1%	0.1%	0.035%	0.045%	0.03%

CHEMICAL PROPERTIES

	Chromium (Cr)	Nickel (Ni)	Manganese (Mn)	Silicone (Si)	Nitrogen (N)	Carbon (C)	Phosphorus (P)	Sulphur (S)
304	18-20%	8-11%	2%	1%	0.1%	0.08%	0.045%	0.03%
304L	18-20%	8-11%	2%	1%	0.1%	0.035%	0.045%	0.03%

MECHANICAL PROPERTIES

	304	304L
Tensile strength (N/mm ²)	500-700	500-700
Yield strength (N/mm ²)	170-220	170-220
Elongation (% in 4D)	40	40
Hardness - Rockwell C (HRC) max	92	92
Hardness - Brinell (HB) max	201	201

MARKET SECTORS



Food Processing

Tanks, pipes, conveyor systems



Chemical Processing

Storage tanks, vessels for chemicals, piping systems



Architectural Applications

Handrails, architectural trim, structural components



Kitchen Equipment

Countertops, sinks, ovens, refrigerators, dishwashers



Pharmaceutical Industry

Surgical instruments, processing equipment and storage



Engineered Components

Fasteners, bolts, valves, fittings

APPLICATIONS

- Fasteners, bolts, screws and nuts
(GENERAL ENGINEERING)
 - Structural elements
(CONSTRUCTION)
 - Fasteners, shafts and axles
(AUTOMOTIVE)
 - Vessels and oil well filter screens
(MARINE EQUIPMENT)
 - Valve stems and bodies, manifolds
(OIL AND GAS INDUSTRY)
- APPLICATIONS ARE INCLUDING, BUT NOT LIMITED TO, THE ABOVE LIST**

MECHANICAL PROPERTIES

	A2-70	A2-80	A2-100
Tensile strength (N/mm ²) min	700	800	1000
Yield strength (N/mm ²) min	500	600	800
Elongation (% in 5D)	-	-	-
Hardness - Rockwell C (HRC) max	-	-	-
Hardness - Brinell (HB) max	-	-	-
Reduction of area (min %)	-	-	-

PHYSICAL PROPERTIES

Density (kg/m ³)	8000	
Modulus of elasticity (Gpa)	193	
Mean coefficient of thermal expansion	0-100°C (µm/m/°C)	17.2
	0-350°C (µm/m/°C)	17.8
	0-538°C (µm/m/°C)	18.4
Thermal conductivity	at 100°C (W/m.K)	16.2
	at 500°C (W/m.K)	21.5
Specific Heat 0-100°C (J/kg.K)	500	
Electrical resistivity (nΩ.m)	720	
Melting point (°C)	1450	

WE CAN COLD DRAW TO CUSTOMERS OWN SPECIFICATIONS.

+44 (0)1922 414003

sales@offshorestainless.co.uk

www.offshorestainless.com



304 – 1.4301 / 304L – 1.4307

304 and 304L are both grades of austenitic stainless steel, which is the most widely used type of stainless steel. These grades are very similar, known for their versatility and corrosion resistance, with the main difference being the carbon content. The use of 304L is often preferred in situations where welding is a significant consideration due to its improved weldability and reduced susceptibility to sensitivity.

KEY FEATURES

- Corrosion resistance
- Forming and welding characteristics
- Oxidation resistance

ASTM A193/A320 B8 CLASS 2/2B, B8X

ASTM A193 and ASTM A320 are specifications that cover alloy and stainless steel bolting materials for high temperature or high pressure service. ASTM A193 B8 refers to a specification for stainless steel bolting materials and ASTM A320 B8 refers to a similar specification often used in low-temperature service. Class 2 and class 2B signifies that the material is strain-hardened.

KEY FEATURES

- Good corrosion resistance
- Good versatility and durability
- Cold workability
- High strength

BAR SHAPES

ROUND BAR:
Ø7.925 – 99.44mm
(0.312 – 3.915")



HEXAGONAL BAR:
10 – 55mm A/F
(0.375 – 2.165")

CHEMICAL PROPERTIES

	Chromium (Cr)	Nickel (Ni)	Manganese (Mn)	Silicone (Si)	Nitrogen (N)	Carbon (C)	Phosphorus (P)	Sulphur (S)
304	18-20%	8-11%	2%	1%	0.1%	0.08%	0.045%	0.03%
304L	18-20%	8-11%	2%	1%	0.1%	0.035%	0.045%	0.03%

CHEMICAL PROPERTIES

	Chromium (Cr)	Nickel (Ni)	Manganese (Mn)	Silicone (Si)	Nitrogen (N)	Carbon (C)	Phosphorus (P)	Sulphur (S)
304	18-20%	8-11%	2%	1%	0.1%	0.08%	0.045%	0.03%
304L	18-20%	8-11%	2%	1%	0.1%	0.035%	0.045%	0.03%

* B8X: Cr 10-19%, Ni 9-12%

MECHANICAL PROPERTIES

	304	304L
Tensile strength (N/mm ²)	500-700	500-700
Yield strength (N/mm ²)	170-220	170-220
Elongation (% in 4D)	40	40
Hardness - Rockwell C (HRC) max	92	92
Hardness - Brinell (HB) max	201	201

PHYSICAL PROPERTIES

Density (kg/m ³)	8000	
Modulus of elasticity (Gpa)	193	
Mean coefficient of thermal expansion	0-100°C (µm/m/°C)	17.2
	0-350°C (µm/m/°C)	17.8
	0-538°C (µm/m/°C)	18.4
Thermal conductivity	at 100°C (W/m.K)	16.2
	at 500°C (W/m.K)	21.5
Specific Heat 0-100°C (J/kg.K)	500	
Electrical resistivity (nΩ.m)	720	
Melting point (°C)	1450	

MARKET SECTORS



Food Processing

Tanks, pipes, conveyor systems



Chemical Processing

Storage tanks, vessels for chemicals, piping systems



Architecture Applications

Handrails, architectural trim, structural components



Kitchen Equipment

Countertops, sinks, ovens, refrigerators, dishwashers



Pharmaceutical Industry

Surgical instruments, processing equipment and storage



Engineered Components

Fasteners, bolts, valves, fittings

APPLICATIONS

- Fasteners, bolts, screws and nuts
(GENERAL ENGINEERING)
- Components used in boilers and turbines
(POWER GENERATION)
- Wellheads, Christmas trees and platforms
(OIL AND GAS INDUSTRY)
- Pipelines, valves and fittings
(PETROCHEMICAL INDUSTRY)
- Heat exchangers
(CHEMICAL PROCESSING)

APPLICATIONS ARE INCLUDING, BUT NOT LIMITED TO, THE ABOVE LIST

MECHANICAL PROPERTIES

	Class 2	Class 2B	B8X
Tensile strength (N/mm ²)	860-690	655-550	860-650
Yield strength (N/mm ²)	690-345	515-380	695-310
Elongation (% in 4D)	12-28	25-30	12-28
Hardness - Rockwell C (HRC) max	35	35	32
Hardness - Brinell (HB) max	321	321	320
Reduction of area (min %)	35-45	40	-

WE CAN COLD DRAW TO CUSTOMERS OWN SPECIFICATIONS.

+44 (0)1922 414003

sales@offshorestainless.co.uk

www.offshorestainless.com

STAINLESS STEEL

316 - 1.4401 / 316L - 1.4404



316 - 1.4401 / 316L - 1.4404

Stainless steel 316 is one of the most widely used and versatile stainless steels, prized for its corrosion resistance and suitability for a broad range of applications. The 316L low carbon content helps reduce the susceptibility to sensitisation during welding, making 316L suitable for applications where post-welding annealing is not practical.

KEY FEATURES

- Excellent corrosion resistance
- Strength and mechanical properties
- Heat resistance
- General weldability

CHEMICAL PROPERTIES

	Chromium (Cr)	Nickel (Ni)	Manganese (Mn)	Molybdenum (Mo)	Silicone (Si)	Nitrogen (N)	Carbon (C)	Phosphorus (P)	Sulphur (S)
316	16-18%	10-12%	2%	2-3%	0.75%	0.1%	0.08%	0.045%	0.03%
316L	16-18%	10-12%	2%	2%	0.75%	0.1%	0.03%	0.045%	0.03%

MECHANICAL PROPERTIES

	316	316L
Tensile strength (N/mm ²)	500-700	500-700
Yield strength (N/mm ²)	170-220	170-220
Elongation (% in 4D)	40	40
Hardness - Rockwell C (HRC) max	92	92
Hardness - Brinell (HB) max	217	217

PHYSICAL PROPERTIES

Density (kg/m ³)	8000
Modulus of elasticity (Gpa)	193
Mean coefficient of thermal expansion	0-100°C (µm/m/°C) 15.9
	0-350°C (µm/m/°C) 16.2
	0-538°C (µm/m/°C) 17.5
Thermal conductivity	at 100°C (W/m.K) 16.3
	at 500°C (W/m.K) 21.5
Specific Heat 0-100°C (J/kg.K)	500
Electrical resistivity (nΩ.m)	740
Melting point (°C)	1450

MARKET SECTORS



Marine Equipment

Boat fittings, hardware, coastal structures



Chemical Processing

Reactors, storage tanks, piping systems, heat exchangers



Medical Devices

Surgical instruments, implants, dental instruments



Food & Beverage Industry

Conveyors, mixers, brewing and distillation equipment



Pharmaceutical Industry

Vessels, reactors, piping systems, processing equipment



Aerospace Industry

Aircraft structural components, engine parts, hardware

COLD DRAWN TO

A4 - 70 / A4 - 80 / A4 - 100

A4 - 70 / A4 - 80 / A4 - 100

A4 grade stainless steels have a slightly higher nickel and molybdenum content than A2 stainless steel. The A4 indicates that it is an austenitic stainless steel, and the following number represents the nominal tensile strength in megapascals (N/mm²) for these materials. They are used for applications that require high strength, precision and durability

KEY FEATURES

- Excellent corrosion resistance
- Increased malleability
- Excellent formability
- Good weldability and durability

CHEMICAL PROPERTIES

	Chromium (Cr)	Nickel (Ni)	Manganese (Mn)	Molybdenum (Mo)	Silicone (Si)	Nitrogen (N)	Carbon (C)	Phosphorus (P)	Sulphur (S)
316	16-18%	10-12%	2%	2-3%	0.75%	0.1%	0.08%	0.045%	0.03%
316L	16-18%	10-12%	2%	2%	0.75%	0.1%	0.03%	0.045%	0.03%

APPLICATIONS

- Fasteners, bolts, screws and nuts
(GENERAL ENGINEERING)
- Structural elements
(CONSTRUCTION)
- Tankers and containers
(CHEMICAL PROCESSING EQUIPMENT)
- Boat fittings, rigging, components
(MARINE EQUIPMENT)
- Food processing equipment
(FOOD AND BEVERAGE INDUSTRY)

APPLICATIONS ARE INCLUDING, BUT NOT LIMITED TO, THE ABOVE LIST

BAR SHAPES

ROUND BAR:
Ø7.925 - 99.44mm
(0.312 - 3.915")

HEXAGONAL BAR:
10 - 55mm A/F
(0.375 - 2.165")



MECHANICAL PROPERTIES

	A4-70	A4-80	A4-100
Tensile strength (N/mm ²) min	700	800	1000
Yield strength (N/mm ²) min	500	600	800
Elongation (% in 5D)	-	-	-
Hardness - Rockwell C (HRC) max	-	-	-
Hardness - Brinell (HB) max	-	-	-
Reduction of area (min %)	-	-	-

WE CAN COLD DRAW TO CUSTOMERS OWN SPECIFICATIONS.

+44 (0)1922 414003

sales@offshorestainless.co.uk

www.offshorestainless.com



316 - 1.4401 / 316L - 1.4404

Stainless steel 316 is one of the most widely used and versatile stainless steels, prized for its corrosion resistance and suitability for a broad range of applications. The 316L low carbon content helps reduce the susceptibility to sensitisation during welding, making 316L suitable for applications where post-welding annealing is not practical.

KEY FEATURES

- Excellent corrosion resistance
- Strength and mechanical properties
- Heat resistance
- General weldability

CHEMICAL PROPERTIES

	Chromium (Cr)	Nickel (Ni)	Manganese (Mn)	Molybdenum (Mo)	Silicone (Si)	Nitrogen (N)	Carbon (C)	Phosphorus (P)	Sulphur (S)
316	16-18%	10-12%	2%	2-3%	0.75%	0.1%	0.08%	0.045%	0.03%
316L	16-18%	10-12%	2%	2%	0.75%	0.1%	0.03%	0.045%	0.03%

MECHANICAL PROPERTIES

	316	316L
Tensile strength (N/mm ²)	500-700	500-700
Yield strength (N/mm ²)	170-220	170-220
Elongation (% in 4D)	40	40
Hardness - Rockwell C (HRC) max	92	92
Hardness - Brinell (HB) max	217	217

PHYSICAL PROPERTIES

Density (kg/m ³)	8000
Modulus of elasticity (Gpa)	193
Mean coefficient of thermal expansion	0-100°C (µm/m/°C) 15.9
	0-350°C (µm/m/°C) 16.2
	0-538°C (µm/m/°C) 17.5
Thermal conductivity	at 100°C (W/m.K) 16.3
	at 500°C (W/m.K) 21.5
Specific Heat 0-100°C (J/kg.K)	500
Electrical resistivity (nΩ.m)	740
Melting point (°C)	1450

MARKET SECTORS



Marine Equipment

Boat fittings, hardware, coastal structures



Chemical Processing

Reactors, storage tanks, piping systems, heat exchangers



Medical Devices

Surgical instruments, implants, dental instruments



Food & Beverage Industry

Conveyors, mixers, brewing and distillation equipment



Pharmaceutical Industry

Vessels, reactors, piping systems, processing equipment



Aerospace Industry

Aircraft structural components, engine parts, hardware

ASTM A193/A320 B8M CLASS 2/2B/2C, B8MX

B8M class 2, 2B and 2C are different classifications based on specific requirements and treatments. Class 2 refers to the basic strain-hardened and cold-worked condition. The 2B designation indicates that it has undergone strain hardening in addition to the carbide solution treatment. B8M Class 2C offers even higher tensile strength compared to the other two classes. B8MX is a designation specified in the BS 4882 standard for stainless steel fasteners.

KEY FEATURES

- Corrosion resistance
- Improved strength
- Wide temperature range suitability
- Reduced sensitisation

BAR SHAPES

ROUND BAR:

Ø7.925 - 99.44mm
(0.312 - 3.915")



HEXAGONAL BAR:

10 - 55mm A/F
(0.375 - 2.165")

CHEMICAL PROPERTIES

	Chromium (Cr)	Nickel (Ni)	Manganese (Mn)	Molybdenum (Mo)	Silicone (Si)	Nitrogen (N)	Carbon (C)	Phosphorus (P)	Sulphur (S)
316	16-18%	10-12%	2%	2-3%	0.75%	0.1%	0.08%	0.045%	0.03%
316L	16-18%	10-12%	2%	2%	0.75%	0.1%	0.03%	0.045%	0.03%

* B8MX: Cr 16.5-18.5%, Ni 10.5-13.5%

APPLICATIONS

- Pipelines, valves and connectors
(OIL AND GAS INDUSTRY)
- Fasteners, bolts, screws and nuts
(GENERAL ENGINEERING)
- Pumps, valves and machinery
(PULP AND PAPER INDUSTRY)
- Bolting components
(POWER GENERATION)
- Pumps, valves and pipelinesent
(CHEMICAL PROCESSING)

APPLICATIONS ARE INCLUDING, BUT NOT LIMITED TO, THE ABOVE LIST

MECHANICAL PROPERTIES

	Class 2	Class 2B	Class 2C
Tensile strength (N/mm ²)	760-620	655-550	585
Yield strength (N/mm ²)	655-345	515-380	450-415
Elongation (% in 4D)	15-30	25-30	30
Hardness - Rockwell C (HRC) max	35	35	35
Hardness - Brinell (HB) max	321	321	321
Reduction of area (min %)	45	40	60

* Dependent upon size

WE CAN COLD DRAW TO CUSTOMERS OWN SPECIFICATIONS.

+44 (0)1922 414003

sales@offshorestainless.co.uk

www.offshorestainless.com



316L - 1.4404

316L stainless steel is a popular type of stainless steel alloy known for its corrosion resistance properties, making it suitable for various applications. It exhibits excellent corrosion resistance, particularly in chloride environments and contains molybdenum, which enhances its resistance to pitting and crevice corrosion.

KEY FEATURES

- Excellent corrosion resistance
- Strength and mechanical properties
- Heat resistance
- General weldability

CHEMICAL PROPERTIES

Chromium (Cr)	Nickel (Ni)	Manganese (Mn)	Molybdenum (Mo)	Silicone (Si)	Nitrogen (N)	Phosphorus (P)	Carbon (C)	Sulphur (S)
16-18%	10-12%	2%	2%	0.75%	0.1%	0.045%	0.03%	0.03%

MECHANICAL PROPERTIES

Tensile strength (N/mm ²)	500-700
Yield strength (N/mm ²)	170-220
Elongation (% in 4D)	40
Hardness - Rockwell C (HRC) max	95
Hardness - Brinell (HB) max	217

PHYSICAL PROPERTIES

Density (kg/m ³)	8000	
Modulus of elasticity (Gpa)	193	
Mean coefficient of thermal expansion	0-100°C (µm/m/°C)	15.9
	0-350°C (µm/m/°C)	16.2
	0-538°C (µm/m/°C)	17.5
Thermal conductivity	at 100°C (W/m.K)	16.3
	at 500°C (W/m.K)	21.5
Specific Heat 0-100°C (J/kg.K)	500	
Electrical resistivity (nΩ.m)	740	
Melting point (°C)	1450	

MARKET SECTORS



Marine Equipment

Boat fittings, hardware, coastal structures



Chemical Processing

Reactors, storage tanks, piping systems, heat exchangers



Medical Devices

Surgical instruments, implants, dental instruments



Food & Beverage Industry

Conveyors, mixers, brewing and distillation equipment



Pharmaceutical Industry

Vessels, reactors, piping systems, processing equipment



Aerospace Industry

Aircraft structural components, engine parts, hardware

316L NACE MR0175

NACE MR0175, also known as ISO 15156, are materials standard issued by the National Association of Corrosion Engineers (NACE). Cold drawn flats and squares conform to NACE MR0175 which was a standard that originated in the US. It assesses the suitability of materials for oilfield equipment in environments where sulfide stress corrosion cracking may occur due to exposure to hydrogen sulfide - commonly referred to as sour environments.

KEY FEATURES

- Sulfide stress cracking (SSC) resistance
- Stress corrosion cracking (SCC) resistance
- Excellent formability
- Good weldability and durability

CHEMICAL PROPERTIES

Chromium (Cr)	Nickel (Ni)	Manganese (Mn)	Molybdenum (Mo)	Silicone (Si)	Nitrogen (N)	Phosphorus (P)	Carbon (C)	Sulphur (S)
16-18%	10-12%	2%	2%	0.75%	0.1%	0.045%	0.03%	0.03%

APPLICATIONS

- Gaskets, pipelines, tubing, gas systems (OIL AND GAS INDUSTRY)
- Valve bodies, manifolds (VALVE COMPONENTS)
- Chemical processing equipment (PETROCHEMICAL INDUSTRY)
- Drilling, completion equipment (MARINE COMPONENTS)
- Pumps, valves and pipelines (CHEMICAL PROCESSING)

APPLICATIONS ARE INCLUDING, BUT NOT LIMITED TO, THE ABOVE LIST

BAR SHAPES

SQUARE BAR:
25.4 - 76.2mm
(1 - 3")

FLAT BAR:
31.75 x 25.4mm -
88.90 x 44.45mm
(1.25 x 1 - 3.5 x 1.75")



MECHANICAL PROPERTIES

Tensile strength (N/mm ²) min	620
Yield strength (N/mm ²) min	480
Elongation (% in 4D) min	30
Hardness - Rockwell C (HRC) max	22
Hardness - Brinell (HB) max	235
Reduction of area (min %)	-

WE CAN COLD DRAW TO CUSTOMERS OWN SPECIFICATIONS.

+44 (0)1922 414003

sales@offshorestainless.co.uk

www.offshorestainless.com



316 TI – 1.4571

Stainless steel 316Ti, also known as 1.4571, is a titanium-stabilised austenitic stainless steel. The “316” designation indicates that it belongs to the 300 series of stainless steels, which are characterised by their austenitic crystalline structure. The addition of titanium (Ti) provides stabilisation against sensitisation and intergranular corrosion, making it suitable for elevated temperature applications.

KEY FEATURES

- Excellent corrosion resistance
- Stability in high temperatures
- Good weldability
- Formability and fabrication
- Good mechanical properties

A5-70 / A5-80

A5 Class 70 and class 80 are property classes achieved by cold drawing the steel bars which, in the context of fasteners, improves the surface finish, dimensional accuracy and mechanical properties of the bars. The higher the class number, the higher the tensile strength of the fastener material.

KEY FEATURES

- Elevated temperature use
- Improved versatility
- Flexibility in fabrication
- Reduced sensitisation risk
- High tensile strength

BAR SHAPES

ROUND BAR:
Ø7.925 – 99.44mm
(0.312 – 3.915”)

HEXAGONAL BAR:
10 – 55mm A/F
(0.375 – 2.165”)



CHEMICAL PROPERTIES

Chromium (Cr)	Nickel (Ni)	Molybdenum (Mo)	Manganese (Mn)	Silicone (Si)	Titanium (Ti)	Nitrogen (N)	Carbon (C)	Phosphorus (P)	Sulphur (S)
16.5–18.5%	10.5–13.5%	2–2.5%	2%	1%	0.2–0.7%	0.1%	0.08%	0.045%	0.03%

CHEMICAL PROPERTIES

Chromium (Cr)	Nickel (Ni)	Molybdenum (Mo)	Manganese (Mn)	Silicone (Si)	Titanium (Ti)	Nitrogen (N)	Carbon (C)	Phosphorus (P)	Sulphur (S)
16.5–18.5%	10.5–13.5%	2–2.5%	2%	1%	0.2–0.7%	0.1%	0.08%	0.045%	0.03%

MECHANICAL PROPERTIES

Tensile strength (N/mm ²)	600
Yield strength (N/mm ²)	450
Elongation (% in 4D)	40
Hardness - Rockwell C (HRC) max	94
Hardness - Brinell (HB) max	215

PHYSICAL PROPERTIES

Density (kg/m ³)	8000	
Modulus of elasticity (Gpa)	193	
Mean coefficient of thermal expansion	0–100°C (µm/m/°C)	15.9
	0–350°C (µm/m/°C)	16.2
	0–538°C (µm/m/°C)	17.5
Thermal conductivity	at 100°C (W/m.K)	16.3
	at 500°C (W/m.K)	21.5
Specific Heat 0–100°C (J/kg.K)	500	
Electrical resistivity (nΩ.m)	740	
Melting point (°C)	1450	

MARKET SECTORS



Pharmaceutical Equipment

Processing equipment, mixing, storage



Chemical Processing

Reactors, vessels, piping systems



Oil & Gas Industry

Platforms, pipelines, tubing, valves



Heat Exchangers

HVAC systems, chemical processing, power generation



Automotive Industry

Exhaust systems, component parts



Food Processing

Tanks, conveyors, mixers, processing machinery

APPLICATIONS

• Pipelines, valves and connectors
(**OIL AND GAS INDUSTRY**)

• Fasteners, bolts, screws and nuts
(**GENERAL ENGINEERING**)

• Pumps, valves and machinery
(**PULP AND PAPER INDUSTRY**)

• Bolting components
(**POWER GENERATION**)

• Pumps, valves and pipelines
(**CHEMICAL PROCESSING**)

APPLICATIONS ARE INCLUDING, BUT NOT LIMITED TO, THE ABOVE LIST

MECHANICAL PROPERTIES

	A5-70	A5-80
Tensile strength (N/mm ²) min	700	800
Yield strength (N/mm ²) min	500	600
Elongation (% in 5D)	-	-
Hardness - Rockwell C (HRC) max	-	-
Hardness - Brinell (HB) max	-	-
Reduction of area (min %)	-	-

WE CAN COLD DRAW TO CUSTOMERS OWN SPECIFICATIONS.

+44 (0)1922 414003

sales@offshorestainless.co.uk

www.offshorestainless.com

STAINLESS STEEL

316L Mo > 2.5% - 1.4435



316L MO>2.5% - 1.4435

Stainless Steel 316L Mo>2.5% - 1.4435 is a type of austenitic stainless steel that has a low carbon content and a high molybdenum content. It is also known as 316L UG or 316L modified. The elevated molybdenum content (greater than 2.5%) in 1.4435 provides enhanced corrosion resistance, especially in aggressive environments containing chlorides.

KEY FEATURES

- Excellent corrosion resistance
- Improved resistance to acids
- Chloride resistance
- Generally weldable
- Formability and fabrication

COLD DRAWN TO

1.4435 Class 70 & 80

1.4435 CLASS 70 & 80

The cold working process increases the strength of the material while maintaining its corrosion resistance. 1.4435 stainless cold drawn to class 70 and class 80 has excellent corrosion resistance, especially in acidic and chloride-containing environments. The process also ensures consistency in dimensions and straightness, making them suitable for applications with specific size requirements.

KEY FEATURES

- Additional corrosion resistance
- Enhanced resistance to pitting and crevice corrosion
- Elevated temperature performance
- Extended service life

BAR SHAPES

ROUND BAR:
Ø7.925 - 99.44mm
(0.312 - 3.915")



HEXAGONAL BAR:
10 - 55mm A/F
(0.375 - 2.165")

CHEMICAL PROPERTIES

Chromium (Cr)	Nickel (Ni)	Molybdenum (Mo)	Manganese (Mn)	Silicone (Si)	Nitrogen (N)	Phosphorus (P)	Carbon (C)	Sulphur (S)
17-19%	12.5-15%	2.5-3%	2%	1%	0.1%	0.045%	0.03%	0.02%

CHEMICAL PROPERTIES

Chromium (Cr)	Nickel (Ni)	Molybdenum (Mo)	Manganese (Mn)	Silicone (Si)	Nitrogen (N)	Phosphorus (P)	Carbon (C)	Sulphur (S)
17-19%	12.5-15%	2.5-3%	2%	1%	0.1%	0.045%	0.03%	0.02%

MECHANICAL PROPERTIES

Tensile strength (N/mm ²)	600
Yield strength (N/mm ²)	450
Elongation (% in 4D)	40
Hardness - Rockwell C (HRC) max	94
Hardness - Brinell (HB) max	215

PHYSICAL PROPERTIES

Density (kg/m ³)	8000	
Modulus of elasticity (Gpa)	193	
Mean coefficient of thermal expansion	0-100°C (µm/m/°C)	17.2
	0-350°C (µm/m/°C)	17.8
	0-538°C (µm/m/°C)	18.4
Thermal conductivity	at 100°C (W/m.K)	15
	at 500°C (W/m.K)	20.8
Specific Heat 0-100°C (J/kg.K)	500	
Electrical resistivity (nΩ.m)	750	
Melting point (°C)	1450	

MARKET SECTORS



Marine Equipment

Boat fittings, hardware



Chemical Processing

Processing equipment, reactors, vessels, piping



Oil & Gas Industry

Platforms, piping, tubing



Food & Beverage Industry

Brewing and distillation, dairy processing



Pharmaceutical Industry

Equipment, storage, transportation vessels



Architectural Applications

Structural components, building facades, handrails, cladding

APPLICATIONS

- Flanges, valves and fittings (HIGH PRESSURE PIPING SYSTEMS)
- Shipbuilding and offshore structures (MARINE EQUIPMENT)
- Exhaust systems, suspension parts (AUTOMOTIVE INDUSTRY)
- Food processing machinery (FOOD & BEVERAGE INDUSTRY)
- Reactors, tanks and pipelines (CHEMICAL PROCESSING)

APPLICATIONS ARE INCLUDING, BUT NOT LIMITED TO, THE ABOVE LIST

MECHANICAL PROPERTIES

	Class 70	Class 80
Tensile strength (N/mm ²) min	700	800
Yield strength (N/mm ²) min	500	600
Elongation (% in 5D)	-	-
Hardness - Rockwell C (HRC) max	-	-
Hardness - Brinell (HB) max	-	-
Reduction of area (min %)	-	-

WE CAN COLD DRAW TO CUSTOMERS OWN SPECIFICATIONS.

+44 (0)1922 414003

sales@offshorestainless.co.uk

www.offshorestainless.com

321 – 1.4541

ASTM A193/A320 B8T Class 2, BS 4882, B8TX



321 – 1.4541

Stainless steel 321, with the designation 1.4541, is a type of austenitic stainless steel that has a high resistance to carbide precipitation and oxidation when exposed to high temperatures. It is stabilised with titanium and has a titanium content of at least five times the carbon content, which prevents intergranular corrosion.

KEY FEATURES

- High temperature resistance
- Good corrosion resistance
- Weldability
- Creep and stress rupture properties
- Good formability and ductility

ASTM A193/A320 B8T CLASS 2, B8TX

ASTM A193/A320 B8T class 2 is a type of stainless steel fastener with corrosion resistance, titanium stabilisation and a specific heat treatment for high tensile strength, high temperature resistance and good corrosion resistance. A193 fasteners are intended for high temperature and high pressure applications, while A320 fasteners are for cold temperature applications.

KEY FEATURES

- High tensile strength
- High temperature performance
- Low temperature service
- Improved versatility
- Enhanced corrosion resistance

BAR SHAPES

ROUND BAR:
Ø7.925 – 99.44mm
(0.312 – 3.915")

HEXAGONAL BAR:
10 – 55mm A/F
(0.375 – 2.165")



CHEMICAL PROPERTIES

Chromium (Cr)	Nickel (Ni)	Manganese (Mn)	Silicone (Si)	Titanium (Ti)	Nitrogen (N)	Carbon (C)	Phosphorus (P)	Sulphur (S)
17-19%	9-12%	2%	1%	0.7%	0.1%	0.08%	0.045%	0.03%

CHEMICAL PROPERTIES

Chromium (Cr)	Nickel (Ni)	Manganese (Mn)	Silicone (Si)	Titanium (Ti)	Nitrogen (N)	Carbon (C)	Phosphorus (P)	Sulphur (S)
17-19%	9-12%	2%	1%	0.7%	0.1%	0.08%	0.045%	0.03%

* B8T Class 2: C + N x 5 = Ti min, B8TX: C x 5 = Ti min

MECHANICAL PROPERTIES

Tensile strength (N/mm ²)	515
Yield strength (N/mm ²)	205
Elongation (% in 4D)	40
Hardness - Rockwell C (HRC) max	95
Hardness - Brinell (HB) max	217

MARKET SECTORS



Food Industry

Equipment, industrial kitchens



Chemical Processing

Reactors, vessels, piping, heat exchangers



Oil & Gas Industry

Components, pipelines, tubing



Power Generation

Boiler tubes, heat exchangers



Automotive Industry

Exhaust systems, catalytic converters



Aerospace Applications

Aircraft exhaust stacks, components

PHYSICAL PROPERTIES

Density (kg/m ³)	7900	
Modulus of elasticity (Gpa)	193	
Mean coefficient of thermal expansion	0-100°C (µm/m/°C)	16.6
	0-350°C (µm/m/°C)	17.2
	0-538°C (µm/m/°C)	18.6
Thermal conductivity	at 100°C (W/m.K)	16.1
	at 500°C (W/m.K)	22.2
Specific Heat 0-100°C (J/kg.K)	500	
Electrical resistivity (nΩ.m)	720	
Melting point (°C)	1450	

APPLICATIONS

- Fasteners, fixings, nuts and bolts (PETROCHEMICAL INDUSTRY)
- Bolting exhaust systems (AUTOMOTIVE INDUSTRY)
- Pressure piping, vessels bolting (POWER GENERATION)
- Annealing equipment, heating elements (CHEMICAL PROCESSING)
- Instruments and construction parts (FOOD & BEVERAGE INDUSTRY)

APPLICATIONS ARE INCLUDING, BUT NOT LIMITED TO, THE ABOVE LIST

MECHANICAL PROPERTIES

	Class 2	B8X
Tensile strength (N/mm ²)	860-690	860-650
Yield strength (N/mm ²)	690-345	695-310
Elongation (%)	12-28 (4D)	12-28 (5D)
Hardness - Rockwell C (HRC) max	35	32
Hardness - Brinell (HB) max	321	320
Reduction of area (min %)	35-45	-

* Dependent upon size

WE CAN COLD DRAW TO CUSTOMERS OWN SPECIFICATIONS.

+44 (0)1922 414003

sales@offshorestainless.co.uk

www.offshorestainless.com

UNS S31254 – 1.4547

ASTM A193/A320 B8MCuN Class 2 / 31254 Class 80



UNS S31254 – 1.4547

UNS S31254, also known as 1.4547 or by its trade names F44 or 254 SMO. It is a high-alloy austenitic stainless steel with excellent corrosion resistance in seawater and various industrial environments, as well as high strength and ductility. It is used for applications such as pumps, valves, chokes, piping, flanges, and chemical processing equipment.

KEY FEATURES

- High corrosion resistance
- High alloy content
- Resistance to reducing acids
- Good mechanical properties
- Good weldability

ASTM A193/A320 B8MCuN CLASS 2 / 31254

ASTM A193/A320 B8MCuN Class 2 / 31254 Class 80 are types of stainless steel fasteners that are made from UNS S31254 6MO / 1.4547 / F44 stainless steel. They have high strength, high temperature resistance, and excellent corrosion resistance in seawater and various industrial environments.

KEY FEATURES

- High temperature performance
- Excellent corrosion resistance
- Resistant to pitting and crevice corrosion
- Resistant to stress corrosion cracking

BAR SHAPES

ROUND BAR:
Ø7.925 – 99.44mm
(0.312 – 3.915")

HEXAGONAL BAR:
10 – 55mm A/F
(0.375 – 2.165")



CHEMICAL PROPERTIES

Chromium (Cr)	Nickel (Ni)	Molybdenum (Mo)	Manganese (Mn)	Copper (Cu)	Silicone (Si)	Nitrogen (N)	Phosphorus (P)	Carbon (C)	Sulphur (S)
19.5–20.5%	17.5–18.5%	6–6.5%	1%	0.5–1%	0.8%	0.18–0.22%	0.03%	0.02%	0.01%

CHEMICAL PROPERTIES

Chromium (Cr)	Nickel (Ni)	Molybdenum (Mo)	Manganese (Mn)	Copper (Cu)	Silicone (Si)	Nitrogen (N)	Phosphorus (P)	Carbon (C)	Sulphur (S)
19.5–20.5%	17.5–18.5%	6–6.5%	1%	0.5–1%	0.8%	0.18–0.22%	0.03%	0.02%	0.01%

MECHANICAL PROPERTIES

Tensile strength (N/mm ²)	700
Yield strength (N/mm ²)	300
Elongation (% in 4D)	35
Hardness - Rockwell C (HRC) max	100
Hardness - Brinell (HB) max	250

PHYSICAL PROPERTIES

Density (kg/m ³)	7900	
Modulus of elasticity (Gpa)	195	
Mean coefficient of thermal expansion	0–100°C (µm/m/°C)	16.5
	0–350°C (µm/m/°C)	17.1
	0–538°C (µm/m/°C)	18.5
Thermal conductivity	at 100°C (W/m.K)	14.0
	at 500°C (W/m.K)	19.3
Specific Heat 0–100°C (J/kg.K)	500	
Electrical resistivity (nΩ.m)	800	
Melting point (°C)	1450	

MARKET SECTORS



Marine Equipment

Boat fittings, hardware, seawater handling



Chemical Processing

Reactors, piping systems, heat exchangers



Oil & Gas Industry

Platforms, pipelines, tubing, valves, fittings



Power Generation

Heat exchangers, boiler tubes, condensers



Pulp & Paper Industry

Digesters, bleach plants, evaporators



Desalination Plants

Evaporators, heat exchangers, components, pumps

APPLICATIONS

- Pressure piping, vessel bolts, flanges
(CHEMICAL PROCESSING)
- Threaded fasteners, countersunk screws
(GENERAL ENGINEERING)
- Steam turbines, boilers and condensers
(POWER GENERATION)
- Offshore platforms and pipelines
(OIL AND GAS INDUSTRY)
- Pumps, piping and heat exchangers
(DESALINATION PLANTS)

APPLICATIONS ARE INCLUDING, BUT NOT LIMITED TO, THE ABOVE LIST

MECHANICAL PROPERTIES

	Class 2	Class 80
Tensile strength (N/mm ²)	760–620	800
Yield strength (N/mm ²)	655–345	600
Elongation (% in 4D)	15–30	-
Hardness - Rockwell C (HRC) max	35	35
Hardness - Brinell (HB) max	321	321
Reduction of area (min %)	45	45

* Dependent upon size

WE CAN COLD DRAW TO CUSTOMERS OWN SPECIFICATIONS.

+44 (0)1922 414003

sales@offshorestainless.co.uk

www.offshorestainless.com



347 – 1.4550

Stainless steel 1.4550, is an austenitic stainless steel alloy that contains niobium (columbium) for stabilisation against intergranular corrosion and oxidation when exposed to high temperatures. It has similar properties and applications as 304 stainless steel, but with better performance at elevated temperatures, and a titanium content of at least five times the carbon content which prevents carbide precipitation.

KEY FEATURES

- High temperature performance
- Oxidation resistance
- Excellent corrosion resistance
- Good weldability
- Good formability and ductility

ASTM A193/A320 B8C CLASS 2

Cold drawn bars of ASTM A193/A320 B8C class 2 are made from 347 stainless steel with niobium stabilisation, which gives them high tensile strength, high temperature resistance, and good corrosion resistance. They are designed for use in special-purpose applications such as pressure piping and pressure vessels bolting.

KEY FEATURES

- High tensile strength
- Creep and stress rupture resistance
- High temperature performance
- Enhanced corrosion resistance
- Reduction of area

BAR SHAPES

ROUND BAR:
Ø7.925 - 99.44mm
(0.312 - 3.915")

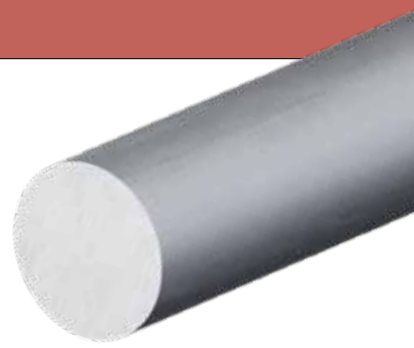

CHEMICAL PROPERTIES

Chromium (Cr)	Nickel (Ni)	Manganese (Mn)	Niobium (Nb)	Silicone (Si)	Carbon (C)	Phosphorus (P)	Sulphur (S)
17-19%	9-12%	2%	1.10%	1%	0.08%	0.045%	0.03%

CHEMICAL PROPERTIES

Chromium (Cr)	Nickel (Ni)	Manganese (Mn)	Niobium (Nb)	Silicone (Si)	Carbon (C)	Phosphorus (P)	Sulphur (S)
17-19%	9-12%	2%	1.10%	1%	0.08%	0.045%	0.03%

* Niobium + Tantalum = C x 10min to 1.10% max

MECHANICAL PROPERTIES

Tensile strength (N/mm ²)	515
Yield strength (N/mm ²)	205
Elongation (% in 4D)	40
Hardness - Rockwell C (HRC) max	92
Hardness - Brinell (HB) max	201

MARKET SECTORS



Automotive Industry

Exhaust systems, catalytic convertors



Chemical Processing

Heat exchangers, condensers, reactors



Oil & Gas Industry

Components, pipelines, tubing, wellhead components



Food Processing

Tanks, conveyors, mixers, machinery



Power Generation

Turbine exhausts systems, boiler tubes, steam piping



Aerospace Applications

Exhaust systems, turbine components

APPLICATIONS

- Pressure piping, vessel bolts, flanges (CHEMICAL PROCESSING)
- Threaded fasteners, bolts, countersunk screws (GENERAL ENGINEERING)
- Reactors, piping systems, distillation columns (PETROLCHEMICAL INDUSTRY)
- Exhaust systems, engine components (AUTOMOTIVE AND AEROSPACE)
- Boiler bolting components, steam turbines (POWER GENERATION)

APPLICATIONS ARE INCLUDING, BUT NOT LIMITED TO, THE ABOVE LIST

MECHANICAL PROPERTIES

Tensile strength (N/mm ²)	862-689
Yield strength (N/mm ²)	690-345
Elongation (% in 4D)	12-28
Hardness - Rockwell C (HRC) max	35
Hardness - Brinell (HB) max	321
Reduction of area (min %)	35-45

WE CAN COLD DRAW TO CUSTOMERS OWN SPECIFICATIONS.

+44 (0)1922 414003

sales@offshorestainless.co.uk

www.offshorestainless.com

SUPER DUPLIX

Super duplex stainless steels are characterised by a two-phase microstructure consisting of both austenitic and ferritic phases, and it is the combination of these phases that provides enhanced mechanical and corrosion-resistant properties compared to traditional austenitic stainless steels.

All our super duplex materials are produced by Norsok M-650 Ed 4 and/or ISO 17782 qualified manufacturers. Super duplex UNS S32760 is among the most common super duplex grades in the market. It is a duplex especially designed for service in aggressive chloride-containing environments. It has very good resistance to localised corrosion and stress corrosion cracking in combination with high mechanical strength.

Common applications for cold drawn super duplex stainless steels include offshore oil and gas platforms, chemical processing plants, desalination facilities, and various marine and industrial applications where corrosion resistance, dimensional accuracy and high strength are critical.

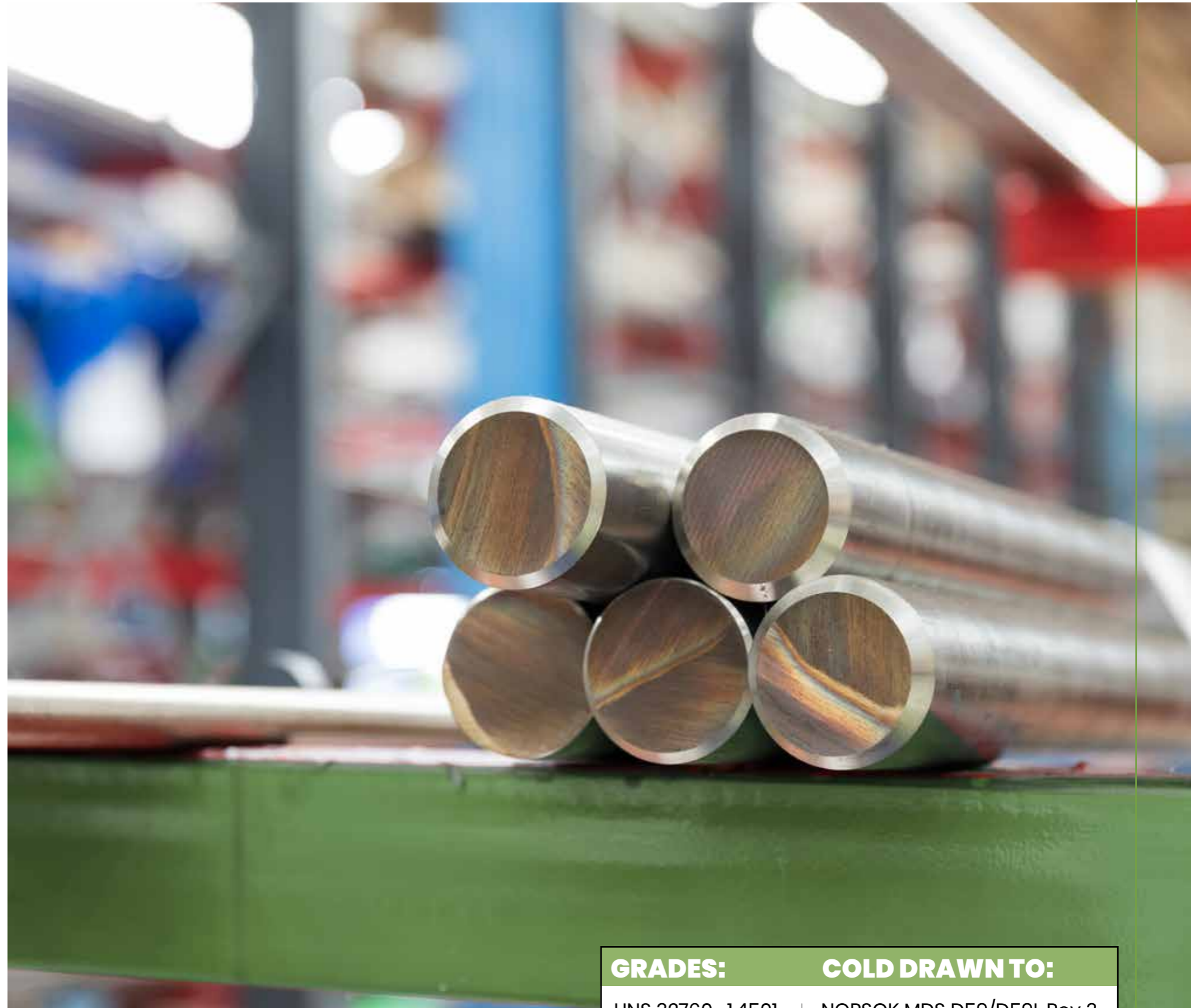

GRADES:	COLD DRAWN TO:
UNS 32760 1.4501	NORSOK MDS D59/D59L Rev 3
UNS 32760 1.4501	32760 FG, FLT, Condition S
UNS 32750 1.4410	32750 FG, FLT Condition S



UNS 32760 - 1.4501

1.4501 is a specific grade of super duplex stainless steel with the common designation for this steel grade of UNS S32760, and it is also referred to as Alloy 2507. The 1.4501 (UNS S32760) super duplex stainless steel belongs to the family of duplex stainless steels, but it is specifically classified as a "super" duplex due to its higher alloy content and enhanced properties.

KEY FEATURES

- Excellent corrosion resistance
- High tensile and yield strength
- Good ductility and toughness
- High temperature resistance
- Pitting and crevice resistance

CHEMICAL PROPERTIES

Chromium (Cr)	Nickel (Ni)	Molybdenum (Mo)	Manganese (Mn)	Silicone (Si)	Tungsten (W)	Copper (Cu)	Nitrogen (N)	Phosphorus (P)	Carbon (C)	Sulphur (S)
24-26%	6-8%	3-4%	1%	1%	1%	0.5-1%	0.25%	0.03%	0.03%	0.01%

MECHANICAL PROPERTIES

Tensile strength (N/mm ²)	750
Yield strength (N/mm ²)	550
Elongation (% in 4D)	25
Hardness - Rockwell C (HRC) max	105
Hardness - Brinell (HB) max	270

PHYSICAL PROPERTIES

Density (kg/m ³)	7800	
Modulus of elasticity (Gpa)	200	
Mean coefficient of thermal expansion	0-100°C (µm/m/°C)	17.2
	0-350°C (µm/m/°C)	17.8
	0-538°C (µm/m/°C)	18.4
Thermal conductivity	at 100°C (W/m.K)	14.2
	at 500°C (W/m.K)	19.6
Specific Heat 0-100°C (J/kg.K)	500	
Electrical resistivity (nΩ.m)	800	
Melting point (°C)	1450	

MARKET SECTORS



Oil & Gas Industry

Pumps, valves, pipes, vessels, wellhead equipment



Desalination Components

Sewage treatment, pumps, valves, piping systems



Marine Equipment

Propellers, shafts, pumps, bolts, fasteners, valves



Chemical Processing

Caustic evaporators, tankers, heat exchangers



Power Generation

Fans, pumps, valves, fasteners, condensers



Pulp & Paper Industry

Digester vessels, bleach towers, equipment

UNS S32760 NORSOK MDS D59/D59L REV 3

This strain hardened grade is only available from qualified sources. The qualification process is verified by AKER to meet the strict requirements set by the NORSOK standard. Repeatability is the key, together with stringent mechanical testing of the finished cold drawn bars. Scan the QR code below to view our Qualification Test Record.

KEY FEATURES

- Enhances strength and hardness
- Excellent corrosion resistance
- High mechanical loads
- Elevated mechanical properties
- Wear resistance

CHEMICAL PROPERTIES

Chromium (Cr)	Nickel (Ni)	Molybdenum (Mo)	Manganese (Mn)	Silicone (Si)	Tungsten (W)	Copper (Cu)	Nitrogen (N)	Phosphorus (P)	Carbon (C)	Sulphur (S)
24-26%	6-8%	3-4%	1%	1%	1%	0.5-1%	0.25%	0.03%	0.03%	0.01%

APPLICATIONS

- Bolts and fasteners (OIL AND GAS INDUSTRY)



SCAN ME

BAR SHAPES

ROUND BAR:
Ø11.38 - 86.74mm
(0.448 - 3.415")



MECHANICAL PROPERTIES

Tensile strength (N/mm ²) min	860
Yield strength (N/mm ²) min	725
Elongation (% in 4D)	16
Hardness - Rockwell C (HRC) max	35
Hardness - Brinell (HB) max	335
Reduction of area (min %)	30

WE CAN COLD DRAW TO CUSTOMERS OWN SPECIFICATIONS.

+44 (0)1922 414003

sales@offshorestainless.co.uk

www.offshorestainless.com



UNS 32760 – 1.4501

1.4501 is a specific grade of super duplex stainless steel with the common designation for this steel grade of UNS S32760, and it is also referred to as Alloy 2507. The 1.4501 (UNS S32760) super duplex stainless steel belongs to the family of duplex stainless steels, but it is specifically classified as a “super” duplex due to its higher alloy content and enhanced properties.

KEY FEATURES

- Excellent corrosion resistance
- High tensile and yield strength
- Good ductility and toughness
- High temperature resistance
- Pitting and crevice resistance

CHEMICAL PROPERTIES

Chromium (Cr)	Nickel (Ni)	Molybdenum (Mo)	Manganese (Mn)	Silicone (Si)	Tungsten (W)	Copper (Cu)	Nitrogen (N)	Phosphorus (P)	Carbon (C)	Sulphur (S)
24-26%	6-8%	3-4%	1%	1%	1%	0.5-1%	0.25%	0.03%	0.03%	0.01%

MECHANICAL PROPERTIES

Tensile strength (N/mm ²)	750
Yield strength (N/mm ²)	550
Elongation (% in 4D)	25
Hardness - Rockwell C (HRC) max	105
Hardness - Brinell (HB) max	270

PHYSICAL PROPERTIES

Density (kg/m ³)	7800	
Modulus of elasticity (Gpa)	200	
Mean coefficient of thermal expansion	0-100°C (µm/m/°C)	17.2
	0-350°C (µm/m/°C)	17.8
	0-538°C (µm/m/°C)	18.4
Thermal conductivity	at 100°C (W/m.K)	14.2
	at 500°C (W/m.K)	19.6
Specific Heat 0-100°C (J/kg.K)	500	
Electrical resistivity (nΩ.m)	800	
Melting point (°C)	1450	

MARKET SECTORS



Oil & Gas Industry

Pumps, valves, pipes, vessels, wellhead equipment



Desalination Components

Sewage treatment, pumps, valves, piping systems



Marine Equipment

Propellers, shafts, pumps, bolts, fasteners, valves



Chemical Processing

Caustic evaporators, tankers, heat exchangers



Power Generation

Fans, pumps, valves, fasteners, condensers



Pulp & Paper Industry

Digester vessels, bleach towers, equipment

UNS 32760 – FG, FLT CONDITION S

For UNS 32760 Super Duplex, also known as 1.4501 & F55, Condition S is the strain hardened condition. Material that is strain hardened to achieve increased mechanical properties will be further designated as variant FG (Fastener Grade) or FLT (Fastener Low Temperature). The grades also require Charpy testing results at -46°C and 101°C respectively.

KEY FEATURES

- Improved durability
- Good corrosion resistance
- Impact toughness
- Good weldability
- Resistance to pitting and crevice corrosion

CHEMICAL PROPERTIES

Chromium (Cr)	Nickel (Ni)	Molybdenum (Mo)	Manganese (Mn)	Silicone (Si)	Tungsten (W)	Copper (Cu)	Nitrogen (N)	Phosphorus (P)	Carbon (C)	Sulphur (S)
24-26%	6-8%	3-4%	1%	1%	1%	0.5-1%	0.25%	0.03%	0.03%	0.01%

APPLICATIONS

- Bars, rods, shafts (PRECISION COMPONENTS)
- Fasteners, bolts, screws and nuts (GENERAL ENGINEERING)
- Pump shafts and water treatment (CHEMICAL PROCESSING)
- Valve stems and bodies (PLUMBING AND AUTOMOTIVE)
- Downhole equipment and tubing (OIL AND GAS INDUSTRY)

APPLICATIONS ARE INCLUDING, BUT NOT LIMITED TO, THE ABOVE LIST

BAR SHAPES

ROUND BAR:
Ø11.38 - 99.44mm
(0.448 - 3.915")



MECHANICAL PROPERTIES

Tensile strength (N/mm ²) min	860
Yield strength (N/mm ²) min	725
Elongation (% in 4D)	16
Hardness - Rockwell C (HRC) max	35
Hardness - Brinell (HB) max	335
Reduction of area (min %)	50

WE CAN COLD DRAW TO CUSTOMERS OWN SPECIFICATIONS.

+44 (0)1922 414003

sales@offshorestainless.co.uk

www.offshorestainless.com

UNS 32750 – 1.4410

UNS 32750 – FG, FLT Condition S



UNS 32750 – 1.4410

UNS 32750, also known as 1.4410, is a Super Duplex Stainless Steel with a combination of excellent mechanical properties and corrosion resistance. UNS 32750 is a highly desirable material for applications requiring superior corrosion resistance, strength and toughness in aggressive environments, making it a preferred choice in critical industries worldwide.

KEY FEATURES

- Excellent corrosion resistance
- High tensile and yield strength
- Good ductility and toughness
- High temperature resistance
- Pitting and crevice resistance

UNS 32750 – FG, FLT CONDITION S

For UNS 32750 Super Duplex, also known as 1.4410, Condition S is the strain hardened condition. Material that is strain hardened to achieve increased mechanical properties will be further designated as variant FG (Fastener Grade) or FLT (Fastener Low Temperature). The grades also require Charpy testing results at -46°C and 101°C respectively.

KEY FEATURES

- Improved durability
- Good corrosion resistance
- Impact toughness
- Good weldability
- Resistance to pitting and crevice corrosion

BAR SHAPES

ROUND BAR:
Ø11.38 – 99.44mm
(0.448 – 3.915")

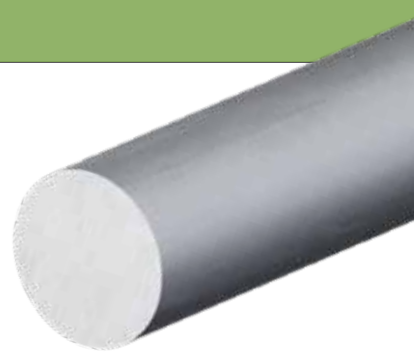

CHEMICAL PROPERTIES

Chromium (Cr)	Nickel (Ni)	Molybdenum (Mo)	Manganese (Mn)	Silicone (Si)	Copper (Cu)	Nitrogen (N)	Phosphorus (P)	Carbon (C)	Sulphur (S)
24.5-26%	6-8%	3-5%	0.5-1%	0.8%	0.5%	0.3%	0.035%	0.03%	0.02%

CHEMICAL PROPERTIES

Chromium (Cr)	Nickel (Ni)	Molybdenum (Mo)	Manganese (Mn)	Silicone (Si)	Copper (Cu)	Nitrogen (N)	Phosphorus (P)	Carbon (C)	Sulphur (S)
24.5-26%	6-8%	3-5%	0.5-1%	0.8%	0.5%	0.3%	0.035%	0.03%	0.02%

MECHANICAL PROPERTIES

Tensile strength (N/mm ²)	800
Yield strength (N/mm ²)	550
Elongation (% in 4D)	25
Hardness - Rockwell C (HRC) max	105
Hardness - Brinell (HB) max	270

PHYSICAL PROPERTIES

Density (kg/m ³)	7810	
Modulus of elasticity (Gpa)	210	
Mean coefficient of thermal expansion	0-100°C (µm/m/°C)	13
	0-350°C (µm/m/°C)	14.1
	0-538°C (µm/m/°C)	15.3
Thermal conductivity	at 100°C (W/m.K)	14.2
	at 500°C (W/m.K)	19.6
Specific Heat 0-100°C (J/kg.K)	457	
Electrical resistivity (nΩ.m)	800	
Melting point (°C)	1350	

MARKET SECTORS



Oil & Gas Industry

Pumps, valves, oil platforms, subsea pipelines



Chemical Processing

Reactors, heat exchangers, vessels



Desalination Components

Seawater intake systems, brine heaters, evaporators



Pulp & Paper Industry

Digester vessels, bleach towers, equipment



Power Generation

Heat exchangers, boilers, condensers



Food Processing

Food handling machinery, storage tanks, equipment

APPLICATIONS

- Bars, rods, shafts (PRECISION COMPONENTS)
- Fasteners, bolts, screws and nuts (GENERAL ENGINEERING)
- Pump shafts and heat exchangers (CHEMICAL PROCESSING)
- Turbines, boilers and condensers (POWER GENERATION)
- Downhole equipment and tubing (OIL AND GAS INDUSTRY)

APPLICATIONS ARE INCLUDING, BUT NOT LIMITED TO, THE ABOVE LIST

MECHANICAL PROPERTIES

Tensile strength (N/mm ²) min	860
Yield strength (N/mm ²) min	725
Elongation (% in 4D)	16
Hardness - Rockwell C (HRC) max	35
Hardness - Brinell (HB) max	335
Reduction of area (min %)	50

WE CAN COLD DRAW TO CUSTOMERS OWN SPECIFICATIONS.

+44 (0)1922 414003

sales@offshorestainless.co.uk

www.offshorestainless.com

DUPLEX STEEL

Material to UNS S31803 is described as a duplex stainless steel with a microstructure 50:50 austenite and ferrite. The steel combines good mechanical strength (typically up to over 480 MPa yield strength) and ductility with moderate to good corrosion resistance in a variety of environments.

By agreement, the alloy can be supplied with a PREN (Pitting Resistance Equivalent Number) at >34 which ensures that the resistance to pitting corrosion is as high as possible for this alloy grade. In addition, the steel offers good resistance to stress corrosion cracking. Ambient and sub-zero temperature notch ductility is also good.

These attributes mean that this duplex steel can be used successfully as an alternative to 300 series stainless steels in applications where higher mechanical strength/lower weight is required and / or resistance to stress corrosion cracking is needed. The machining and welding of this grade of duplex stainless steel presents no particular problems.

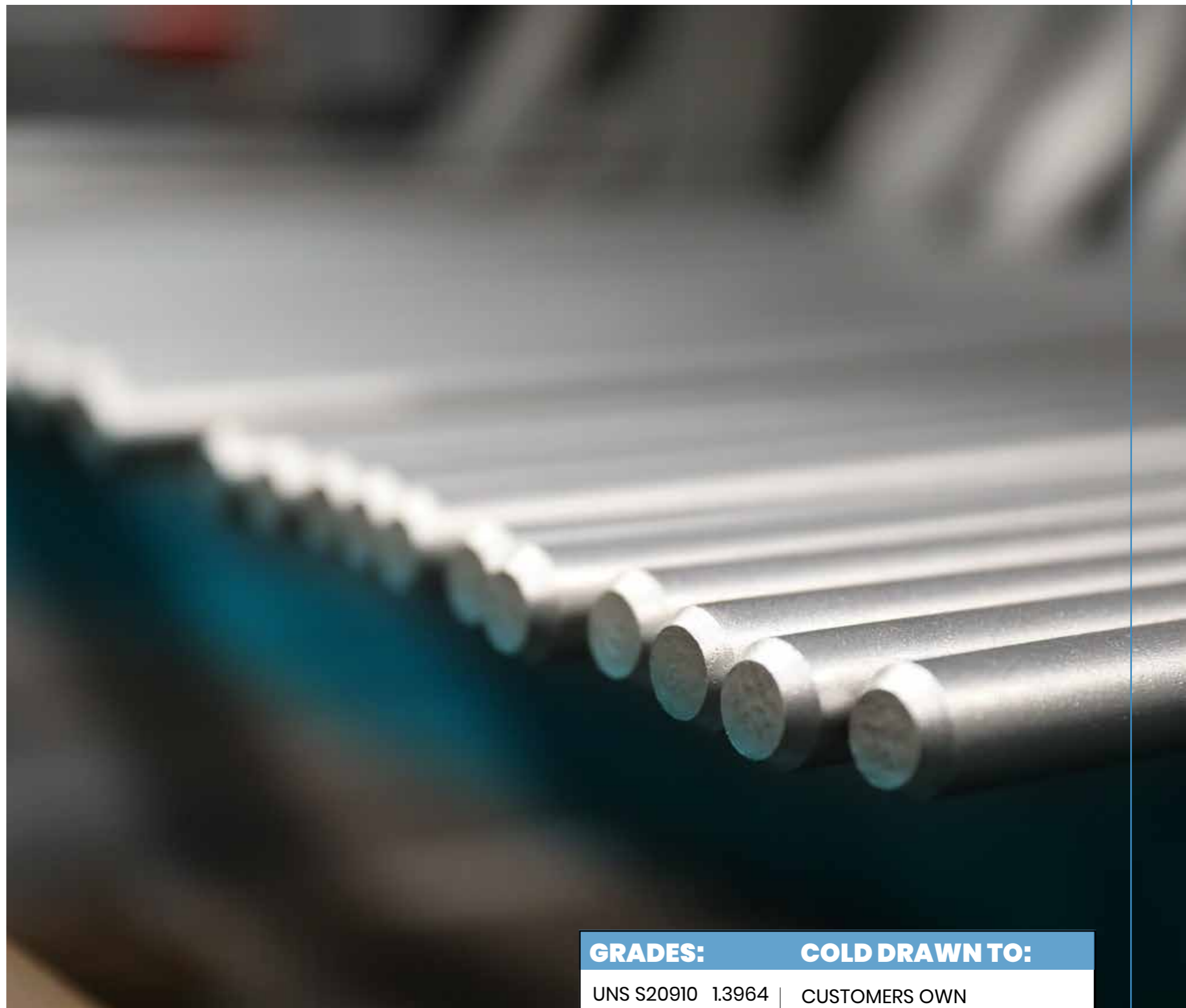

GRADES:		COLD DRAWN TO:
UNS S20910	1.3964	CUSTOMERS OWN SPECIFICATIONS AND PROPERTIES
UNS S31803	1.4462	

DUPLEX

UNS S20910 - 1.3964

BAR SHAPES

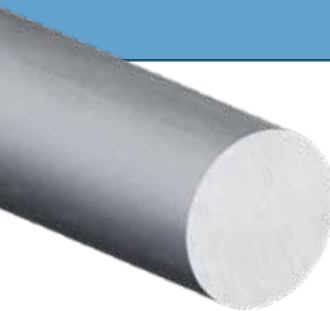

ROUND BAR:
Ø11.38 - 99.44mm
(0.448 - 3.915")

UNS S20910 - 1.3964

Duplex steel 1.3964 is a stainless steel that has high strength and corrosion resistance. It is also known as Nitronic 50, XM-19, or 1.396412 and contains more chromium, nickel, molybdenum, and nitrogen than regular stainless steels, which gives it better resistance to pitting, crevice corrosion, and stress corrosion cracking.

KEY FEATURES

- Good mechanical properties
- High corrosion resistance in coastal environments
- Moderately low thermal conductivity

COLD DRAWN TO CUSTOMERS OWN SPECIFICATIONS AND PROPERTIES

CHEMICAL PROPERTIES

Chromium (Cr)	Nickel (Ni)	Manganese (Mn)	Molybdenum (Mo)	Silicone (Si)	Copper (Cu)	Carbon (C)	Nitrogen (N)	Vanadium (V)	Niobium (Nb)	Phosphorus (P)	Sulphur (S)
20-22%	11.5-13.5%	4-6%	3-3.5%	1%	0.5-1%	0.03%	0.25%	0.2%	0.2%	0.025%	0.01%

MECHANICAL PROPERTIES

Tensile strength (N/mm ²)	700-950
Yield strength (N/mm ²)	370
Elongation (% in 4D)	35
Hardness - Rockwell C (HRC) max	110
Hardness - Brinell (HB) max	293

PHYSICAL PROPERTIES

Density (kg/m ³)	7900	
Modulus of elasticity (Gpa)	195	
Mean coefficient of thermal expansion	0-100°C (µm/m/°C)	15.7
	0-350°C (µm/m/°C)	17.2
	0-538°C (µm/m/°C)	18.0
Thermal conductivity	at 100°C (W/m.K)	14.0
	at 500°C (W/m.K)	19.3
Specific Heat 0-100°C (J/kg.K)	460	
Electrical resistivity (nΩ.m)	810	
Melting point (°C)	1450	

MARKET SECTORS



Marine Components

Boat shafts, propellers, fasteners



Chemical Processing

Pumps, valves, components



Oil & Gas Industry

Valves, fittings, downhole equipment



Mechanical Components

Springs, bolts, fasteners



Aerospace Industry

Fittings, fasteners, structural elements



Power Generation

Components in power plants, turbine blades, shafts

DUPLEX

UNS 31803 - 1.4462

BAR SHAPES

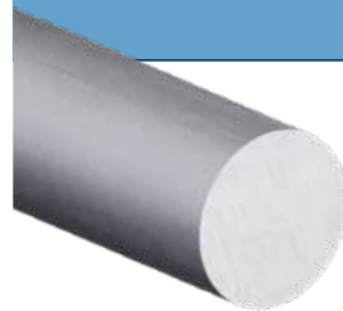

ROUND BAR:
Ø11.38 - 99.44mm
(0.448 - 3.915")

UNS 31803 - 1.4462

UNS 31803 is a type of Duplex stainless steel that has a balanced microstructure of 50% austenite and 50% ferrite. Also known as F51 or 2205, this grade is a successful alternative to the normal 300 series austenitic stainless steels, where its higher strength and resistance to stress corrosion cracking is required in critical applications.

KEY FEATURES

- High corrosion resistance
- High strength
- Good weldability
- Good mechanical strength

COLD DRAWN TO CUSTOMERS OWN SPECIFICATIONS AND PROPERTIES

CHEMICAL PROPERTIES

Chromium (Cr)	Nickel (Ni)	Molybdenum (Mo)	Manganese (Mn)	Silicone (Si)	Copper (Cu)	Phosphorus (P)	Carbon (C)	Sulphur (S)	Nitrogen (N)
21-23%	4.5-6.5%	2.5-3.5%	2%	1%	0.5-1%	0.035%	0.03%	0.02%	0.15%

MECHANICAL PROPERTIES

Tensile strength (N/mm ²)	650-880
Yield strength (N/mm ²)	450
Elongation (% in 4D)	25
Hardness - Rockwell C (HRC) max	105
Hardness - Brinell (HB) max	270

PHYSICAL PROPERTIES

Density (kg/m ³)	7800	
Modulus of elasticity (Gpa)	200	
Mean coefficient of thermal expansion	0-100°C (µm/m/°C)	13.0
	0-350°C (µm/m/°C)	13.4
	0-538°C (µm/m/°C)	14.1
Thermal conductivity	100°C (W/m.K)	15.0
	500°C (W/m.K)	20.2
Specific Heat 0-100°C (J/kg.K)	500	
Electrical resistivity (nΩ.m)	800	
Melting point (°C)	1450	

MARKET SECTORS



Marine Equipment

Ship hulls, propeller shafts, fasteners



Chemical Processing

Plant equipment, reactors, columns, vessels



Oil & Gas Industry

Pumps, valves, chokes, piping systems



Pulp & Paper Industry

Digesters, bleaching tanks, piping systems



Power Generation

Bolts, fasteners, connectors



Petrochemical Industry

Heat exchangers, tanks, piping equipment

NICKEL ALLOYS

A nickel alloy is a type of metal that contains nickel as one of its primary elements. It is typically alloyed with other metals to create a material with specific properties such as high strength, corrosion resistance and excellent performance at high temperatures.

The addition of specific elements imparts unique properties to nickel alloys, making them suitable for challenging environments and demanding conditions. It is often used in extreme working environments, such as those encountered in the aerospace, chemical processing, and petroleum industries, but can also be used in electrical applications.

The cold drawing process enhances the mechanical properties of nickel alloys while maintaining or improving their corrosion resistance. This makes cold drawn nickel alloys suitable for demanding applications in industries where precise dimensions, improved mechanical properties, and enhanced surface finish are required.



GRADES:		COLD DRAWN TO:
C22	2.4602	CUSTOMERS OWN SPECIFICATIONS AND PROPERTIES
C276	2.4819	
400	2.4360	
K500	2.4375	
625	2.4856	
718	2.4668	
725	2.7725	
X750	2.4669	
825	2.4858	

NICKEL ALLOY

C22 – 2.4602

BAR SHAPES

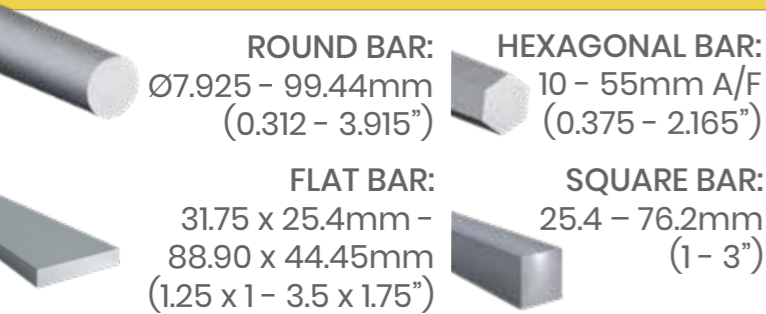

C22 – 2.4602

Nickel Alloy C22, also known as Hastelloy C22, is a nickel-chromium-molybdenum alloy with the UNS N06022 designation. It is known for its exceptional corrosion resistance in highly aggressive environments and is often chosen for applications where resistance to both oxidising and reducing acids is required, especially in marine and chemical environments.

KEY FEATURES

- Excellent corrosion resistance
- Highly versatile
- High temperature stability
- Good weldability

COLD DRAWN TO CUSTOMERS OWN SPECIFICATIONS AND PROPERTIES

CHEMICAL PROPERTIES

Nickel (Ni)	Chromium (Cr)	Molybdenum (Mo)	Iron (Fe)	Tungsten (W)	Cobalt (Co)	Manganese (Mn)	Vanadium (V)	Phosphorus (P)	Silicone (Si)	Carbon (C)	Sulphur (S)
50-63%	20-22.5%	12.5-14.5%	2-6%	2.5-3.5%	2.5%	0.5%	0.35%	0.015%	0.01%	0.01%	0.01%

MECHANICAL PROPERTIES

Tensile strength (N/mm ²)	765
Yield strength (N/mm ²)	359
Elongation (% in 4D)	25
Hardness - Rockwell C (HRC) max	35
Hardness - Brinell (HB) max	320

PHYSICAL PROPERTIES

Density (kg/m ³)	8650	
Modulus of elasticity (Gpa)	206	
Mean coefficient of thermal expansion	0-100°C (µm/m/°C)	6.9
	0-350°C (µm/m/°C)	7.2
	0-538°C (µm/m/°C)	7.5
Thermal conductivity	at 100°C (W/m.k)	10.2
	at 500°C (W/m.k)	13.1
Specific Heat 0-100°C (J/kg.k)	414	
Electrical resistivity (nΩ.m)	448	
Melting point (°C)	1400	

MARKET SECTORS

Pollution Control

Scrubbers, ducts, stacks in air pollution control systems

Chemical Processing

Reactors, vessels, piping systems

Oil & Gas Industry

Components for sour gas applications

Marine Industry

Marine shafts, valves, fasteners

Pharmaceutical Industry

Equipment for handling corrosive substances

Aerospace Industry

Valves, fasteners, electrical components

NICKEL ALLOY

C276 – 2.4819

BAR SHAPES

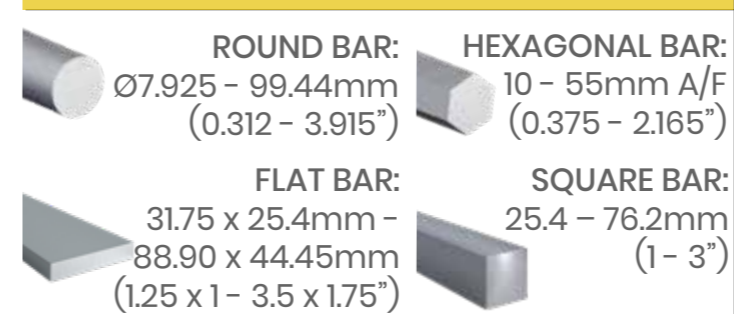

C276 – 2.4819

Nickel Alloy C276, or material number 2.4819, is a corrosion-resistant nickel-molybdenum-chromium alloy with an addition of tungsten. This alloy, often referred to as Hastelloy C276, is known for its excellent resistance to a wide range of severe, corrosive environments, including strong acids, chlorides, and reducing conditions, making it suitable for various challenging applications.

KEY FEATURES

- Exceptional corrosion resistance
- Excellent resistance to oxidation
- Good mechanical properties at high temperature
- Easily fabricated

COLD DRAWN TO CUSTOMERS OWN SPECIFICATIONS AND PROPERTIES

CHEMICAL PROPERTIES

Molybdenum (Mo)	Chromium (Cr)	Iron (Fe)	Tungsten (W)	Cobalt (Co)	Manganese (Mn)	Silicone (Si)	Vanadium (V)	Carbon (C)	Sulphur (S)	Nickel (Ni)
15-17%	15-16.5%	4-7%	3-4.5	2.5%	1%	0.08%	0.1-0.3%	0.01%	0.01%	Rest

MECHANICAL PROPERTIES

Tensile strength (N/mm ²)	750
Yield strength (N/mm ²)	310
Elongation (% in 4D)	30
Hardness - Rockwell C (HRC) max	87
Hardness - Brinell (HB) max	-

PHYSICAL PROPERTIES

Density (kg/m ³)	8600	
Modulus of elasticity (Gpa)	208	
Mean coefficient of thermal expansion	0-100°C (µm/m/°C)	11.2
	0-350°C (µm/m/°C)	11.8
	0-538°C (µm/m/°C)	12.5
Thermal conductivity	at 100°C (W/m.k)	10.4
	at 500°C (W/m.k)	13.1
Specific Heat 0-100°C (J/kg.k)	415	
Electrical resistivity (nΩ.m)	125	
Melting point (°C)	1350	

MARKET SECTORS

Chemical Processing

Reactors and vessels, pipes, fittings, and valves in chemical plants

Pulp & Paper Industry

Components exposed to corrosive chemicals

Pharmaceutical Industry

Production vessels, equipment

Oil & Gas Industry

Equipment for handling sour gas, pipes, valves

Waste Treatment

Components in waste treatment facilities

Power Generation

Flue gas desulphurisation units, heat exchangers

NICKEL ALLOY

400 – 2.4360

BAR SHAPES

ROUND BAR:
Ø7.925 – 99.44mm
(0.312 – 3.915")

400 – 2.4360

Nickel alloy 400 is a single phase, solid-solution nickel-copper alloy that offers superior resistance to many corrosive environments over temperatures ranging from sub-zero to 800°F. It is known for its resistance to corrosion, especially in environments where hydrofluoric acid and fluorine gases are present, and is only hardenable through cold working, rather than heat treatment.

KEY FEATURES

- Excellent corrosion resistance
- High ductility
- Good mechanical properties
- Thermal stability
- Non-magnetic

COLD DRAWN TO CUSTOMERS OWN SPECIFICATIONS AND PROPERTIES

CHEMICAL PROPERTIES

Nickel (Ni)	Copper (Cu)	Iron (Fe)	Manganese (Mn)	Silicone (Si)	Carbon (C)	Sulphur (S)
63%	28-34%	2.5%	2%	0.5%	0.3%	0.03%

MECHANICAL PROPERTIES

Tensile strength (N/mm ²)	700
Yield strength (N/mm ²)	310
Elongation (% in 4D)	35
Hardness - Rockwell C (HRC) max	80
Hardness - Brinell (HB) max	-

PHYSICAL PROPERTIES

Density (kg/m ³)	8800	
Modulus of elasticity (Gpa)	173	
Mean coefficient of thermal expansion	0-100°C (µm/m/°C)	13.9
	0-350°C (µm/m/°C)	14.6
	0-538°C (µm/m/°C)	15.3
Thermal conductivity	at 100°C (W/m.K)	21.8
	at 500°C (W/m.K)	26.2
Specific Heat 0-100°C (J/kg.K)	427	
Electrical resistivity (nΩ.m)	547	
Melting point (°C)	1350	

MARKET SECTORS



Marine Equipment

Heat exchangers, condensers, fixtures, fasteners



Chemical Processing

Tanks, pumps, valves, reactors, vessels, heat exchangers



Oil & Gas Industry

Components for downhole and surface applications



Electrical Industry

Electrical components, springs, connectors



Aerospace Industry

Aircraft components, missile systems, aircraft fuel tanks



Food Processing

Food handling machinery, storage tanks, processing vessels

NICKEL ALLOY

K500 – 2.4375

BAR SHAPES

ROUND BAR:
Ø7.925 – 99.44mm
(0.312 – 3.915")

K500 – 2.4375

Nickel Alloy K500, also known as 2.4375 or Monel K500, is a nickel-copper alloy that can be age-hardened by adding aluminum and titanium. It is known for its resistance to corrosion and its ability to maintain good mechanical properties in challenging environments, especially in marine and chemical environments, and high strength at elevated temperatures.

KEY FEATURES

- Excellent corrosion resistance
- High strength
- Non-magnetic
- Good ductility and toughness
- Low magnetic permeability

COLD DRAWN TO CUSTOMERS OWN SPECIFICATIONS AND PROPERTIES

CHEMICAL PROPERTIES

Nickel (Ni)	Copper (Cu)	Aluminium (Al)	Iron (Fe)	Manganese (Mn)	Silicone (Si)	Titanium (Ti)	Carbon (C)	Sulphur (S)
63%	27-33%	2.3-3.2%	2%	1.5%	0.5%	0.35-0.85%	0.25%	0.1%

MECHANICAL PROPERTIES

Tensile strength (N/mm ²)	1100
Yield strength (N/mm ²)	790
Elongation (% in 4D)	20
Hardness - Rockwell C (HRC) max	34
Hardness - Brinell (HB) max	315

PHYSICAL PROPERTIES

Density (kg/m ³)	8440	
Modulus of elasticity (Gpa)	179	
Mean coefficient of thermal expansion	0-100°C (µm/m/°C)	13.4
	0-350°C (µm/m/°C)	13.9
	0-538°C (µm/m/°C)	14.5
Thermal conductivity	at 100°C (W/m.K)	17.2
	at 500°C (W/m.K)	20.1
Specific Heat 0-100°C (J/kg.K)	418	
Electrical resistivity (nΩ.m)	242	
Melting point (°C)	1350	

MARKET SECTORS



Marine Equipment

Marine shafts, valves, fasteners, pump and valve components



Chemical Processing

Reactors, vessels, heat exchangers, piping systems



Oil & Gas Industry

Downhole equipment, pump shafts, valve stems, tubing



Electrical Industry

Electrical connectors, springs, switchgear components



Aerospace Industry

Fasteners, springs, parts, missile systems, fuel tanks



Power Generation

Turbine components, blades, boiler feedwater systems

NICKEL ALLOY

625 – 2.4856

BAR SHAPES



ROUND BAR:
Ø7.925 - 99.44mm
(0.312 - 3.915")

625 – 2.4856

Nickel Alloy 625, also known by its material number 2.4856, is a corrosion-resistant nickel-chromium-molybdenum alloy with an addition of niobium, with significant strength and toughness. It is often referred to simply as Inconel 625, and it exhibits excellent resistance to a wide range of corrosive environments, making it suitable for various applications.

KEY FEATURES

- Highly corrosion resistant
- Excellent resistance to oxidation
- Resistance to pitting and crevice corrosion
- High temperature strength

COLD DRAWN TO CUSTOMERS OWN SPECIFICATIONS AND PROPERTIES

CHEMICAL PROPERTIES

Chromium (Cr)	Molybdenum (Mo)	Iron (Fe)	Niobium (Nb)	Cobalt (Co)	Manganese (Mn)	Silicone (Si)	Carbon (C)	Nickel (Ni)
21-23%	8-10%	5%	3.2-3.8%	1%	0.5%	0.4%	0.03%	Rest

MECHANICAL PROPERTIES

Tensile strength (N/mm ²)	827
Yield strength (N/mm ²)	413
Elongation (% in 4D)	30
Hardness - Rockwell C (HRC) max	35
Hardness - Brinell (HB) max	320

PHYSICAL PROPERTIES

Density (kg/m ³)	8440	
Modulus of elasticity (Gpa)	205	
Mean coefficient of thermal expansion	0-100°C (µm/m/°C)	12.8
	0-350°C (µm/m/°C)	13.4
	0-538°C (µm/m/°C)	14.1
Thermal conductivity	at 100°C (W/m.K)	9.8
	at 500°C (W/m.K)	12.7
Specific Heat 0-100°C (J/kg.K)	410	
Electrical resistivity (nΩ.m)	125	
Melting point (°C)	1350	

MARKET SECTORS



Chemical Processing

Reactors, vessels, piping, heat exchangers



Marine Equipment

Propeller blades, seawater piping systems, valves



Oil & Gas Industry

Equipment for sour gas, downhole tubing and casing in wells



Power Generation

Steam turbine shroud rings, seals, components



Nuclear Industry

Reactors components, fuel handling systems



Aerospace Industry

Ducting systems, exhaust systems, rocket motors

NICKEL ALLOY

718 – 2.4668

BAR SHAPES

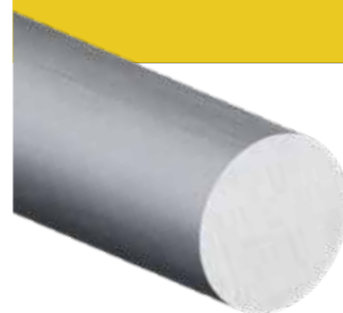

ROUND BAR:
Ø7.925 - 99.44mm
(0.312 - 3.915")

718 – 2.4668

Nickel Alloy 718, with the designation UNS N07718 and the DIN/EN designation 2.4668, is a precipitation-hardening nickel-chromium alloy. It has excellent resistance to corrosion and oxidation, as well as high tensile and fatigue strength at high temperatures, and is widely used in aerospace, oil and gas, and other high-performance applications.

KEY FEATURES

- High strength
- Good corrosion resistance
- High temperature stability
- Good weldability

COLD DRAWN TO CUSTOMERS OWN SPECIFICATIONS AND PROPERTIES

CHEMICAL PROPERTIES

Nickel (Ni)	Chromium (Cr)	Niobium (Nb)	Molybdenum (Mo)	Cobalt (Co)	Titanium (Ti)	Manganese (Mn)	Silicone (Si)	Copper (Cu)	Aluminium (Al)	Phosphorus (P)	Carbon (C)	Sulphur (S)	Iron (Fe)
50-55%	17-21%	4.75-5.5%	2.8-3.3%	1%	0.65-1.15%	0.35%	0.35%	0.30%	0.2-0.8%	0.15%	0.08%	0.02%	Rest

MECHANICAL PROPERTIES

Tensile strength (N/mm ²)	725
Yield strength (N/mm ²)	325
Elongation (% in 4D)	30
Hardness - Rockwell C (HRC) max	36
Hardness - Brinell (HB) max	331

PHYSICAL PROPERTIES

Density (kg/m ³)	8220	
Modulus of elasticity (Gpa)	200	
Mean coefficient of thermal expansion	0-100°C (µm/m/°C)	12.8
	0-350°C (µm/m/°C)	13.4
	0-538°C (µm/m/°C)	14.1
Thermal conductivity	at 100°C (W/m.K)	11.4
	at 500°C (W/m.K)	14.3
Specific Heat 0-100°C (J/kg.K)	435	
Electrical resistivity (nΩ.m)	132	
Melting point (°C)	1335	

MARKET SECTORS



Automotive Industry

Turbocharger rotors, fasteners, components



Power Generation

Gas turbine components, cryogenic tanks



Oil & Gas Industry

Downhole equipment, wellhead components, oil well tools



Medical Industry

Surgical instruments, medical implants, components



Nuclear Industry

Reactors, nuclear fuel elements



Aerospace Industry

Turbine disks, engine parts, structural elements

NICKEL ALLOY

725 – 2.7725

BAR SHAPES

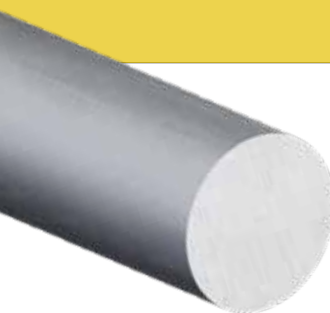

ROUND BAR:
Ø7.925 – 99.44mm
(0.312 – 3.915")

725 – 2.7725

Alloy 725 2.7725 is a nickel-chromium-molybdenum-niobium aged hardenable grade with extremely high strength. Alloy 725 was developed from Alloy 625 by adding strengthening elements aluminium and titanium to enhance its mechanical properties and for ductility and toughness. In addition, the alloy has high corrosion resistance including resistance to hydrogen embrittlement and stress corrosion cracking.

KEY FEATURES

- High strength and toughness
- High temperature resistance
- Good resistance to oxidation
- Corrosion resistance

COLD DRAWN TO CUSTOMERS OWN SPECIFICATIONS AND PROPERTIES

CHEMICAL PROPERTIES

Nickel (Ni)	Chromium (Cr)	Molybdenum (Mo)	Niobium (Nb)	Titanium (Ti)	Aluminium (Al)	Manganese (Mn)	Silicone (Si)	Carbon (C)	Phosphorus (P)	Sulphur (S)	Iron (Fe)
55–59%	19–22.5%	7–9.5%	2.75–4%	1–1.7	0.35%	0.35%	0.2%	0.03%	0.015%	0.01%	Rest

MECHANICAL PROPERTIES

Tensile strength (N/mm ²)	1241
Yield strength (N/mm ²)	903
Elongation (% in 4D)	31
Hardness – Rockwell C (HRC) max	36
Hardness – Brinell (HB) max	331

PHYSICAL PROPERTIES

Density (kg/m ³)	8300	
Modulus of elasticity (Gpa)	204	
Mean coefficient of thermal expansion	0–100°C (µm/m/°C)	13
	0–350°C (µm/m/°C)	13.6
	0–538°C (µm/m/°C)	14.3
Thermal conductivity	at 100°C (W/m.K)	10.6
	at 500°C (W/m.K)	13.6
Specific Heat 0–100°C (J/kg.K)	430	
Electrical resistivity (nΩ.m)	115	
Melting point (°C)	1345	

MARKET SECTORS



Aerospace Industry

Turbine blades, discs, shafts, structural components



Marine & Shipbuilding

High strength fasteners, subsea equipment



Oil & Gas Industry

Fasteners, valves, pumps, landing nipples, side pocket mandrels



Chemical Processing

Reactors, vessels, heat exchangers, piping systems



Power Generation

Turbine discs, blades, shafts, nuclear power plants



Petrochemical Industry

Distillation columns, catalyst support systems

NICKEL ALLOY

X750 – 2.4669

BAR SHAPES



ROUND BAR:
Ø7.925 – 99.44mm
(0.312 – 3.915")

X750 – 2.4669

Nickel Alloy X750 is a high-strength and versatile nickel-chromium alloy with excellent corrosion and oxidation resistance at elevated temperatures. It can be precipitation-hardened through heat treatment, and the alloy can be easily fabricated using standard techniques for nickel-based alloys. However, its high strength may require special considerations during machining.

KEY FEATURES

- Good corrosion resistance
- Resistance to oxidation
- Good high temperature strength
- Easily fabricated

COLD DRAWN TO CUSTOMERS OWN SPECIFICATIONS AND PROPERTIES

CHEMICAL PROPERTIES

Nickel (Ni)	Chromium (Cr)	Iron (Fe)	Titanium (Ti)	Manganese (Mn)	Cobalt (Co)	Niobium (Nb)	Aluminium (Al)	Silicone (Si)	Copper (Cu)	Carbon (C)	Sulphur (S)
70%	14–17%	5–9%	2.25–2.75%	1%	1%	0.7–1.2%	0.4–1%	0.5%	0.5%	0.08%	0.01%

MECHANICAL PROPERTIES

Tensile strength (N/mm ²)	744
Yield strength (N/mm ²)	365
Elongation (% in 4D)	30
Hardness – Rockwell C (HRC) max	35
Hardness – Brinell (HB) max	320

PHYSICAL PROPERTIES

Density (kg/m ³)	8260	
Modulus of elasticity (Gpa)	195	
Mean coefficient of thermal expansion	0–100°C (µm/m/°C)	14.2
	0–350°C (µm/m/°C)	15.2
	0–538°C (µm/m/°C)	15.5
Thermal conductivity	at 100°C (W/m.K)	10.0
	at 500°C (W/m.K)	12.9
Specific Heat 0–100°C (J/kg.K)	430	
Electrical resistivity (nΩ.m)	122	
Melting point (°C)	1425	

MARKET SECTORS



Chemical & Petrochemical

Heat exchangers, chemical processing vessels



Fasteners & Fixings

High performance springs, connectors, valves



Oil & Gas Industry

Downhole tools, wellhead components, valves



Automotive Industry

Exhaust systems components, turbocharger parts, valves



Nuclear Industry

Reactors for components, control rod components



Aerospace Industry

Gas turbine engines, turbine blades, seals, discs, casings

NICKEL ALLOY

825 – 2.4858

YOUR NOTES

BAR SHAPES



ROUND BAR:
Ø7.925 - 99.44mm
(0.312 - 3.915")

825 – 2.4858

Nickel Alloy 825 is a nickel-iron-chromium alloy with additions of molybdenum, copper and titanium. Commonly referred to as Incoloy 825, this alloy is recognised for its excellent corrosion resistance in challenging environments, including those with sulfuric and phosphoric acids, and outstanding resistance to pitting and crevice corrosion, as well as to chloride-ion stress corrosion cracking.

**COLD DRAWN TO CUSTOMERS
OWN SPECIFICATIONS
AND PROPERTIES**

KEY FEATURES

- Excellent corrosion resistance
- High temperature resistance
- Optimal longevity in challenging environments
- Weldable

CHEMICAL PROPERTIES

Nickel (Ni)	Chromium (Cr)	Iron (Fe)	Molybdenum (Mo)	Copper (Cu)	Manganese (Mn)	Titanium (Ti)	Silicone (Si)	Aluminium (Al)	Carbon (C)	Sulphur (S)
38-46%	19.5-23.5%	22%	2.5-3.5%	1.5-3%	1%	0.6-1.2	0.5%	0.2%	0.05%	0.03%

MECHANICAL PROPERTIES

Tensile strength (N/mm ²)	590
Yield strength (N/mm ²)	241
Elongation (% in 4D)	30
Hardness - Rockwell C (HRC) max	35
Hardness - Brinell (HB) max	320

PHYSICAL PROPERTIES

Density (kg/m ³)	8140	
Modulus of elasticity (Gpa)	196	
Mean coefficient of thermal expansion	0-100°C (µm/m/°C)	14.0
	0-350°C (µm/m/°C)	14.9
	0-538°C (µm/m/°C)	15.4
Thermal conductivity	at 100°C (W/m.K)	11.1
	at 500°C (W/m.K)	13.5
Specific Heat 0-100°C (J/kg.K)	440	
Electrical resistivity (nΩ.m)	113	
Melting point (°C)	1400	

MARKET SECTORS



Chemical Processing

Reactors, vessels, heat exchangers, piping systems, valves



Marine Equipment

Seawater piping systems, heat exchangers, valves, ship fittings



Oil & Gas Industry

Equipment for sour gas, tubing and piping



Power Generation

Heat exchangers, steam generators, components

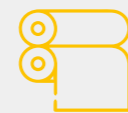

Pulp & Paper Industry

Digesters, bleach plants, processing equipment



Pollution Control

Scrubbers, ductwork, waste incinerators, reactors



Steel Dynamics Group[®]
Family of Companies

The Steel Dynamics Group Family of Companies consists of four businesses, relentlessly working together to reduce our customer's costs enabling UK manufacturing to flourish.



The Steel Dynamics group offer our customers instant access to a comprehensive inventory of non-ferrous metal product lines. The group strategy is to deliver profitable growth by leveraging our businesses in to emerging markets in the UK and worldwide.

We operate a best practice regime, which means continuous improvement in processes and sustainable manufacturing, quality standards, customer service and new technologies. This consistent investment allows us to review the cost base to be lean, efficient and competitive.

With recent acquisitions, new premises, investments in capital equipment and significant stock holding in stainless steel, aluminium, copper and brass, it's a great time to talk to the group about what we can do for you.



Steel Dynamics UK[®]

The UK's leading stainless steel stockholder and processor, supplying a range of mainstream stainless steel profiles to complex supply chains.



Offshore
Stainless Supplies

A reputable manufacturer & stockholder of cold drawn stainless steel and nickel alloy bars, as well as being the largest stockholder of 1.4003 stainless steel.



P&P NON-FERROUS
SINCE 1983

Specialists in aluminium, brass, bronze, copper, phosphor bronze and stainless steel, all held in stock and processed to customer requirements.



Universally recognised as the 'Best in Brass', Bornmore Metals also carry a very impressive inventory of multi-metals, available for immediate delivery.

“Let's work together to build a brighter, more sustainable future.”



Head Office

Unit 12, Paget Way
Burntwood Bus. Park
Burntwood
Staffordshire
WS7 3FS

Manufacturing Site

Toll Point
Lichfield Road
Brownhills
Walsall
WS8 6JZ

☎ +44 (0)1922 414 003

✉ sales@offshorestainless.co.uk

🌐 www.offshorestainless.com



A Member of the
Steel Dynamics Group[®]
Family of Companies